

■ Contributing Zone Plan

Bandera Ranch

Helotes, Bexar County, Texas

March 2024

Project Owner:

Helotes Bandera Ranch, LP

1509 Old West 38th Street

Suite 3, Austin, TX 78731

Email: cthigpen@paravelcap.com

Contact: Curtis Thigpen



Prepared By:

Kimley»»Horn

10101 Reunion Place, Suite 400

San Antonio, TX 78216

(210) 541-9166

KHA No. 064468910

TABLE OF CONTENTS

EDWARDS AQUIFER APPLICATION COVER PAGE	SECTION 1
EDWARDS AQUIFER APPLICATION COVER PAGE.....	3
CONTRIBUTING ZONE PLAN APPLICATION	SECTION 2
CONTRIBUTING ZONE PLAN APPLICATION	7
Road Map.....	Attachment A
USGS Quadrangle Map.....	Attachment B
Project Narrative.....	Attachment C
Factors Affecting Surface Water Quality.....	Attachment D
Volume and Character of Stormwater	Attachment E
Suitability Letter from authorized Agent.....	Attachment F
Alternative Secondary Containment Methods	Attachment G
AST Containment Structure Drawings.....	Attachment H
20% or Less Impervious Cover	Attachment I
BMPs for Upgradient Stormwater	Attachment J
BMPs for On-Site Stormwater	Attachment K
BMPs for Surface Streams	Attachment L
Construction Plans.....	Attachment M
Inspections, Maintenance, Repair and Retrofit Plan.....	Attachment N
Pilot-Scale Field Testing Plan	Attachment O
Measures for Minimizing Surface Stream Contamination.....	Attachment P
TCEQ General Construction Notes.....	Attachment Q
TEMPORARY STORMWATER	SECTION 3
TEMPORARY STORMWATER	47
Spill Response Actions.....	Attachment A
Potential Sources of Contamination	Attachment B
Sequence of Major Activities.....	Attachment C
Temporary Best Management Practices and Measure	Attachment D
Request to Temporarily Seal a Feature	Attachment E
Structural Practices	Attachment F
Drainage Area Map	Attachment G
Temporary Sediment Pond(s) Plans and Calculations.....	Attachment H
Inspection and Maintenance for BMPs	Attachment I
Schedule of Interim and Permanent Soil Stabilization Practices	Attachment J
ADDITIONAL FORMS	SECTION 4
COPY OF NOTICE OF INTENT (NOI).....	68
AGENT AUTHORIZATION FORM	89
APPLICATION FEE FORM	91
Check Payable to the “Texas Commission on Environmental Quality”	
CORE DATA FORMS	93

Texas Commission on Environmental Quality

Edwards Aquifer Application Cover Page

Our Review of Your Application

The Edwards Aquifer Program staff conducts an administrative and technical review of all applications. The turnaround time for administrative review can be up to 30 days as outlined in 30 TAC 213.4(e). Generally administrative completeness is determined during the intake meeting or within a few days of receipt. The turnaround time for technical review of an administratively complete Edwards Aquifer application is 90 days as outlined in 30 TAC 213.4(e). Please know that the review and approval time is directly impacted by the quality and completeness of the initial application that is received. In order to conduct a timely review, it is imperative that the information provided in an Edwards Aquifer application include final plans, be accurate, complete, and in compliance with [30 TAC 213](#).

Administrative Review

1. [Edwards Aquifer applications](#) must be deemed administratively complete before a technical review can begin. To be considered administratively complete, the application must contain completed forms and attachments, provide the requested information, and meet all the site plan requirements. The submitted application and plan sheets should be final plans. Please submit one full-size set of plan sheets with the original application, and half-size sets with the additional copies.

To ensure that all applicable documents are included in the application, the program has developed tools to guide you and web pages to provide all forms, checklists, and guidance. Please visit the below website for assistance: <http://www.tceq.texas.gov/field/eapp>.

2. This Edwards Aquifer Application Cover Page form (certified by the applicant or agent) must be included in the application and brought to the administrative review meeting.
3. Administrative reviews are scheduled with program staff who will conduct the review. Applicants or their authorized agent should call the appropriate regional office, according to the county in which the project is located, to schedule a review. The average meeting time is one hour.
4. In the meeting, the application is examined for administrative completeness. Deficiencies will be noted by staff and emailed or faxed to the applicant and authorized agent at the end of the meeting, or shortly after. Administrative deficiencies will cause the application to be deemed incomplete and returned.

An appointment should be made to resubmit the application. The application is re-examined to ensure all deficiencies are resolved. The application will only be deemed administratively complete when all administrative deficiencies are addressed.

5. If an application is received by mail, courier service, or otherwise submitted without a review meeting, the administrative review will be conducted within 30 days. The applicant and agent will be contacted with the results of the administrative review. If the application is found to be administratively incomplete, it can be retrieved from the regional office or returned by regular mail. If returned by mail, the regional office may require arrangements for return shipping.
6. If the geologic assessment was completed before October 1, 2004 and the site contains “possibly sensitive” features, the assessment must be updated in accordance with the *Instructions to Geologists* (TCEQ-0585 Instructions).

Technical Review

1. When an application is deemed administratively complete, the technical review period begins. The regional office will distribute copies of the application to the identified affected city, county, and groundwater conservation district whose jurisdiction includes the subject site. These entities and the public have 30 days to provide comments on the application to the regional office. All comments received are reviewed by TCEQ.
2. A site assessment is usually conducted as part of the technical review, to evaluate the geologic assessment and observe existing site conditions. The site must be accessible to our staff. The site boundaries should be

clearly marked, features identified in the geologic assessment should be flagged, roadways marked and the alignment of the Sewage Collection System and manholes should be staked at the time the application is submitted. If the site is not marked the application may be returned.

3. We evaluate the application for technical completeness and contact the applicant and agent via Notice of Deficiency (NOD) to request additional information and identify technical deficiencies. There are two deficiency response periods available to the applicant. There are 14 days to resolve deficiencies noted in the first NOD. If a second NOD is issued, there is an additional 14 days to resolve deficiencies. If the response to the second notice is not received, is incomplete or inadequate, or provides new information that is incomplete or inadequate, the application must be withdrawn or will be denied. Please note that because the technical review is underway, whether the application is withdrawn or denied **the application fee will be forfeited.**
4. The program has 90 calendar days to complete the technical review of the application. If the application is technically adequate, such that it complies with the Edwards Aquifer rules, and is protective of the Edwards Aquifer during and after construction, an approval letter will be issued. Construction or other regulated activity may not begin until an approval is issued.

Mid-Review Modifications

It is important to have final site plans prior to beginning the permitting process with TCEQ to avoid delays.

Occasionally, circumstances arise where you may have significant design and/or site plan changes after your Edwards Aquifer application has been deemed administratively complete by TCEQ. This is considered a “Mid-Review Modification”. Mid-Review Modifications may require redistribution of an application that includes the proposed modifications for public comment.

If you are proposing a Mid-Review Modification, two options are available:

- If the technical review has begun your application can be denied/withdrawn, your fees will be forfeited, and the plan will have to be resubmitted.
- TCEQ can continue the technical review of the application as it was submitted, and a modification application can be submitted at a later time.

If the application is denied/withdrawn, the resubmitted application will be subject to the administrative and technical review processes and will be treated as a new application. The application will be redistributed to the affected jurisdictions.

Please contact the regional office if you have questions. If your project is located in Williamson, Travis, or Hays County, contact TCEQ’s Austin Regional Office at 512-339-2929. If your project is in Comal, Bexar, Medina, Uvalde, or Kinney County, contact TCEQ’s San Antonio Regional Office at 210-490-3096

Please fill out all required fields below and submit with your application.

1. Regulated Entity Name: Bandera Ranch				2. Regulated Entity No.: 111858122					
3. Customer Name: Helotes Bandera Ranch, LP				4. Customer No.: 606209005					
5. Project Type: (Please circle/check one)	<u>New</u>		Modification			Extension		Exception	
6. Plan Type: (Please circle/check one)	WPAP	<u>CZP</u>	SCS	UST	AST	EXP	EXT	Technical Clarification	Optional Enhanced Measures
7. Land Use: (Please circle/check one)	Residential		<u>Non-residential</u>			8. Site (acres):		31.463	
9. Application Fee:	\$6,500		10. Permanent BMP(s):				Batch Detention Basin		
11. SCS (Linear Ft.):	N/A		12. AST/UST (No. Tanks):				N/A		
13. County:	Bexar		14. Watershed:				Leon Creek		

Application Distribution

Instructions: Use the table below to determine the number of applications required. One original and one copy of the application, plus additional copies (as needed) for each affected incorporated city, county, and groundwater conservation district are required. Linear projects or large projects, which cross into multiple jurisdictions, can require additional copies. Refer to the “Texas Groundwater Conservation Districts within the EAPP Boundaries” map found at:

http://www.tceq.texas.gov/assets/public/compliance/field_ops/eapp/EAPP%20GWCD%20map.pdf

For more detailed boundaries, please contact the conservation district directly.

Austin Region			
County:	Hays	Travis	Williamson
Original (1 req.)	—	—	—
Region (1 req.)	—	—	—
County(ies)	—	—	—
Groundwater Conservation District(s)	<input type="checkbox"/> Edwards Aquifer Authority <input type="checkbox"/> Barton Springs/Edwards Aquifer <input type="checkbox"/> Hays Trinity <input type="checkbox"/> Plum Creek	<input type="checkbox"/> Barton Springs/Edwards Aquifer	NA
City(ies) Jurisdiction	<input type="checkbox"/> Austin <input type="checkbox"/> Buda <input type="checkbox"/> Dripping Springs <input type="checkbox"/> Kyle <input type="checkbox"/> Mountain City <input type="checkbox"/> San Marcos <input type="checkbox"/> Wimberley <input type="checkbox"/> Woodcreek	<input type="checkbox"/> Austin <input type="checkbox"/> Bee Cave <input type="checkbox"/> Pflugerville <input type="checkbox"/> Rollingwood <input type="checkbox"/> Round Rock <input type="checkbox"/> Sunset Valley <input type="checkbox"/> West Lake Hills	<input type="checkbox"/> Austin <input type="checkbox"/> Cedar Park <input type="checkbox"/> Florence <input type="checkbox"/> Georgetown <input type="checkbox"/> Jerrell <input type="checkbox"/> Leander <input type="checkbox"/> Liberty Hill <input type="checkbox"/> Pflugerville <input type="checkbox"/> Round Rock

San Antonio Region					
County:	Bexar	Comal	Kinney	Medina	Uvalde
Original (1 req.)	<u>X</u>	—	—	—	—
Region (1 req.)	<u>X</u>	—	—	—	—
County(ies)	<u>X</u>	—	—	—	—
Groundwater Conservation District(s)	<input checked="" type="checkbox"/> Edwards Aquifer Authority <input checked="" type="checkbox"/> Trinity-Glen Rose	<input type="checkbox"/> Edwards Aquifer Authority	<input type="checkbox"/> Kinney	<input type="checkbox"/> EAA <input type="checkbox"/> Medina	<input type="checkbox"/> EAA <input type="checkbox"/> Uvalde
City(ies) Jurisdiction	<input type="checkbox"/> Castle Hills <input type="checkbox"/> Fair Oaks Ranch <input checked="" type="checkbox"/> Helotes <input type="checkbox"/> Hill Country Village <input type="checkbox"/> Hollywood Park <input type="checkbox"/> San Antonio (SAWS) <input type="checkbox"/> Shavano Park	<input type="checkbox"/> Bulverde <input type="checkbox"/> Fair Oaks Ranch <input type="checkbox"/> Garden Ridge <input type="checkbox"/> New Braunfels <input type="checkbox"/> Schertz	NA	<input type="checkbox"/> San Antonio ETJ (SAWS)	NA

I certify that to the best of my knowledge, that the application is complete and accurate. This application is hereby submitted to TCEQ for administrative review and technical review.

Matthew G. Matney, P.E.

Print Name of Customer/Authorized Agent

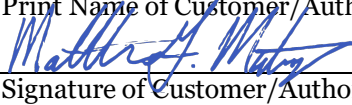

4/15/2024

Signature of Customer/Authorized Agent

Date

****FOR TCEQ INTERNAL USE ONLY****

Date(s) Reviewed:		Date Administratively Complete:	
Received From:		Correct Number of Copies:	
Received By:		Distribution Date:	
EAPP File Number:		Complex:	
Admin. Review(s) (No.):		No. AR Rounds:	
Delinquent Fees (Y/N):		Review Time Spent:	
Lat./Long. Verified:		SOS Customer Verification:	
Agent Authorization Complete/Notarized (Y/N):		Fee Check:	Payable to TCEQ (Y/N):
Core Data Form Complete (Y/N):			Signed (Y/N):
Core Data Form Incomplete Nos.:			Less than 90 days old (Y/N):

Contributing Zone Plan Application

Texas Commission on Environmental Quality

for Regulated Activities on the Contributing Zone to the Edwards Aquifer and Relating to 30 TAC §213.24(1), Effective June 1, 1999

To ensure that the application is administratively complete, confirm that all fields in the form are complete, verify that all requested information is provided, consistently reference the same site and contact person in all forms in the application, and ensure forms are signed by the appropriate party.

Note: Including all the information requested in the form and attachments contributes to more streamlined technical reviews.

Signature

To the best of my knowledge, the responses to this form accurately reflect all information requested concerning the proposed regulated activities and methods to protect the Edwards Aquifer. This Contributing Zone Plan Application is hereby submitted for TCEQ review and Executive Director approval. The application was prepared by:

Print Name of Customer/Agent: Matthew G. Matney, P.E.

Date: 03/29/2024

Signature of Customer/Agent:



Regulated Entity Name: Bandera Ranch

Project Information

1. County: Bexar
2. Stream Basin: San Antonio River Basin
3. Groundwater Conservation District (if applicable): Trinity-Glen Rose & Edwards Aquifer Authority

4. Customer (Applicant):

Contact Person: Curtis Thigpen

Entity: Helotes Bandera Ranch, LP

Mailing Address: 1509 Old West 38th St., Suite 3

City, State: Austin, TX

Telephone: 512-934-8293

Zip: 78731

Fax: _____

Email Address: cthigpen@paravelcap.com

5. Agent/Representative (If any):

Contact Person: Matthew G. Matney, P.E.

Entity: Kimley-Horn and Associates

Mailing Address: 10101 Reunion Place, Suite 400

City, State: San Antonio, TX

Zip: 78216

Telephone: 210-321-3419

Fax: _____

Email Address: matthew.matney@kimley-horn.com

6. Project Location:

The project site is located inside the city limits of Helotes.

The project site is located outside the city limits but inside the ETJ (extra-territorial jurisdiction) of _____.

The project site is not located within any city's limits or ETJ.

7. The location of the project site is described below. Sufficient detail and clarity has been provided so that the TCEQ's Regional staff can easily locate the project and site boundaries for a field investigation.

8. Attachment A - Road Map. A road map showing directions to and the location of the project site is attached. The map clearly shows the boundary of the project site.

9. Attachment B - USGS Quadrangle Map. A copy of the official 7 ½ minute USGS Quadrangle Map (Scale: 1" = 2000") is attached. The map(s) clearly show:

Project site boundaries.

USGS Quadrangle Name(s).

10. Attachment C - Project Narrative. A detailed narrative description of the proposed project is attached. The project description is consistent throughout the application and contains, at a minimum, the following details:

Area of the site

Offsite areas

Impervious cover

Permanent BMP(s)

Proposed site use

Site history

Previous development

Area(s) to be demolished

11. Existing project site conditions are noted below:

Existing commercial site

- Existing industrial site
- Existing residential site
- Existing paved and/or unpaved roads
- Undeveloped (Cleared)
- Undeveloped (Undisturbed/Not cleared)
- Other: _____

12. The type of project is:

- Residential: # of Lots: _____
- Residential: # of Living Unit Equivalents: 230 units
- Commercial
- Industrial
- Other: _____

13. Total project area (size of site): 31.463 Acres

Total disturbed area: 27.693 Acres

14. Estimated projected population: 525 Daily Trip Rates based on ITE land use code and description.

15. The amount and type of impervious cover expected after construction is complete is shown below:

Table 1 - Impervious Cover

<i>Impervious Cover of Proposed Project</i>	<i>Sq. Ft.</i>	<i>Sq. Ft./Acre</i>	<i>Acres</i>
Structures/Rooftops	223,898	÷ 43,560 =	5.10
Parking	104,544	÷ 43,560 =	2.40
Other paved surfaces	357,192	÷ 43,560 =	8.20
Total Impervious Cover	685,634	÷ 43,560 =	15.70

Total Impervious Cover 15.70 ÷ Total Acreage 31.463 X 100 = 50% Impervious Cover

- 16. Attachment D - Factors Affecting Surface Water Quality. A detailed description of all factors that could affect surface water quality is attached. If applicable, this includes the location and description of any discharge associated with industrial activity other than construction.
- 17. Only inert materials as defined by 30 TAC 330.2 will be used as fill material.

For Road Projects Only

Complete questions 18 - 23 if this application is exclusively for a road project.

N/A

18. Type of project:

- TXDOT road project.
- County road or roads built to county specifications.
- City thoroughfare or roads to be dedicated to a municipality.
- Street or road providing access to private driveways.

19. Type of pavement or road surface to be used:

- Concrete
- Asphaltic concrete pavement
- Other: _____

20. Right of Way (R.O.W.):

Length of R.O.W.: _____ feet.

Width of R.O.W.: _____ feet.

$L \times W = \text{_____ Ft}^2 \div 43,560 \text{ Ft}^2/\text{Acre} = \text{_____ acres.}$

21. Pavement Area:

Length of pavement area: _____ feet.

Width of pavement area: _____ feet.

$L \times W = \text{_____ Ft}^2 \div 43,560 \text{ Ft}^2/\text{Acre} = \text{_____ acres.}$

Pavement area _____ acres \div R.O.W. area _____ acres $\times 100 = \text{_____}\%$ impervious cover.

22. A rest stop will be included in this project.

A rest stop will not be included in this project.

23. Maintenance and repair of existing roadways that do not require approval from the TCEQ Executive Director. Modifications to existing roadways such as widening roads/adding shoulders totaling more than one-half (1/2) the width of one (1) existing lane require prior approval from the TCEQ.

Stormwater to be generated by the Proposed Project

24. Attachment E - Volume and Character of Stormwater. A detailed description of the volume (quantity) and character (quality) of the stormwater runoff which is expected to occur from the proposed project is attached. The estimates of stormwater runoff quality and quantity are based on area and type of impervious cover. Include the runoff coefficient of the site for both pre-construction and post-construction conditions.

Wastewater to be generated by the Proposed Project

25. Wastewater is to be discharged in the contributing zone. Requirements under 30 TAC §213.6(c) relating to Wastewater Treatment and Disposal Systems have been satisfied.

N/A

26. Wastewater will be disposed of by:

On-Site Sewage Facility (OSSF/Septic Tank):

Attachment F - Suitability Letter from Authorized Agent. An on-site sewage facility will be used to treat and dispose of the wastewater from this site. The appropriate licensing authority's (authorized agent) written approval is attached. It states that the land is suitable for the use of private sewage facilities and will meet or exceed the requirements for on-site sewage facilities as specified under 30 TAC Chapter 285 relating to On-site Sewage Facilities.

Each lot in this project/development is at least one (1) acre (43,560 square feet) in size. The system will be designed by a licensed professional engineer or registered sanitarian and installed by a licensed installer in compliance with 30 TAC Chapter 285.

Sewage Collection System (Sewer Lines):

The sewage collection system will convey the wastewater to the Leon Creek (name) Treatment Plant. The treatment facility is:

Existing.

Proposed.

N/A

Permanent Aboveground Storage Tanks (ASTs) ≥ 500 Gallons

Complete questions 27 - 33 if this project includes the installation of AST(s) with volume(s) greater than or equal to 500 gallons.

N/A

27. Tanks and substance stored:

Table 2 - Tanks and Substance Storage

<i>AST Number</i>	<i>Size (Gallons)</i>	<i>Substance to be Stored</i>	<i>Tank Material</i>
1			
2			
3			

<i>AST Number</i>	<i>Size (Gallons)</i>	<i>Substance to be Stored</i>	<i>Tank Material</i>
4			
5			

Total x 1.5 = _____ Gallons

28. The AST will be placed within a containment structure that is sized to capture one and one-half (1 1/2) times the storage capacity of the system. For facilities with more than one tank system, the containment structure is sized to capture one and one-half (1 1/2) times the cumulative storage capacity of all systems.

Attachment G - Alternative Secondary Containment Methods. Alternative methods for providing secondary containment are proposed. Specifications showing equivalent protection for the Edwards Aquifer are attached.

29. Inside dimensions and capacity of containment structure(s):

Table 3 - Secondary Containment

<i>Length (L)(Ft.)</i>	<i>Width(W)(Ft.)</i>	<i>Height (H)(Ft.)</i>	<i>L x W x H = (Ft3)</i>	<i>Gallons</i>

Total: _____ Gallons

30. Piping:

- All piping, hoses, and dispensers will be located inside the containment structure.
- Some of the piping to dispensers or equipment will extend outside the containment structure.
- The piping will be aboveground
- The piping will be underground

31. The containment area must be constructed of and in a material impervious to the substance(s) being stored. The proposed containment structure will be constructed of: _____.

32. Attachment H - AST Containment Structure Drawings. A scaled drawing of the containment structure is attached that shows the following:

- Interior dimensions (length, width, depth and wall and floor thickness).
- Internal drainage to a point convenient for the collection of any spillage.
- Tanks clearly labeled
- Piping clearly labeled

- Dispenser clearly labeled
- 33. Any spills must be directed to a point convenient for collection and recovery. Spills from storage tank facilities must be removed from the controlled drainage area for disposal within 24 hours of the spill.
 - In the event of a spill, any spillage will be removed from the containment structure within 24 hours of the spill and disposed of properly.
 - In the event of a spill, any spillage will be drained from the containment structure through a drain and valve within 24 hours of the spill and disposed of properly. The drain and valve system are shown in detail on the scaled drawing.

Site Plan Requirements

Items 34 - 46 must be included on the Site Plan.

- 34. The Site Plan must have a minimum scale of 1" = 400'.
Site Plan Scale: 1" = 60'.
- 35. 100-year floodplain boundaries:
 - Some part(s) of the project site is located within the 100-year floodplain. The floodplain is shown and labeled.
 - No part of the project site is located within the 100-year floodplain.
The 100-year floodplain boundaries are based on the following specific (including date of material) sources(s): 48029C0205G eff. 09/29/2010.
- 36. The layout of the development is shown with existing and finished contours at appropriate, but not greater than ten-foot contour intervals. Lots, recreation centers, buildings, roads, etc. are shown on the site plan.
 - The layout of the development is shown with existing contours at appropriate, but not greater than ten-foot contour intervals. Finished topographic contours will not differ from the existing topographic configuration and are not shown. Lots, recreation centers, buildings, roads, etc. are shown on the site plan.
- 37. A drainage plan showing all paths of drainage from the site to surface streams.
- 38. The drainage patterns and approximate slopes anticipated after major grading activities.
- 39. Areas of soil disturbance and areas which will not be disturbed.
- 40. Locations of major structural and nonstructural controls. These are the temporary and permanent best management practices.
- 41. Locations where soil stabilization practices are expected to occur.
- 42. Surface waters (including wetlands).
 - N/A

43. Locations where stormwater discharges to surface water.
 There will be no discharges to surface water.
44. Temporary aboveground storage tank facilities.
 Temporary aboveground storage tank facilities will not be located on this site.
45. Permanent aboveground storage tank facilities.
 Permanent aboveground storage tank facilities will not be located on this site.
46. Legal boundaries of the site are shown.

Permanent Best Management Practices (BMPs)

Practices and measures that will be used during and after construction is completed.

47. Permanent BMPs and measures must be implemented to control the discharge of pollution from regulated activities after the completion of construction.
 N/A
48. These practices and measures have been designed, and will be constructed, operated, and maintained to insure that 80% of the incremental increase in the annual mass loading of total suspended solids (TSS) from the site caused by the regulated activity is removed. These quantities have been calculated in accordance with technical guidance prepared or accepted by the executive director.
 The TCEQ Technical Guidance Manual (TGM) was used to design permanent BMPs and measures for this site.
 A technical guidance other than the TCEQ TGM was used to design permanent BMPs and measures for this site. The complete citation for the technical guidance that was used is: _____.
 N/A
49. Owners must insure that permanent BMPs and measures are constructed and function as designed. A Texas Licensed Professional Engineer must certify in writing that the permanent BMPs or measures were constructed as designed. The certification letter must be submitted to the appropriate regional office within 30 days of site completion.
 N/A
50. Where a site is used for low density single-family residential development and has 20 % or less impervious cover, other permanent BMPs are not required. This exemption from permanent BMPs must be recorded in the county deed records, with a notice that if the percent impervious cover increases above 20% or land use changes, the exemption for the whole site as described in the property boundaries required by 30 TAC §213.4(g) (relating to Application Processing and Approval), may no longer apply and the property owner must notify the appropriate regional office of these changes.

- The site will be used for low density single-family residential development and has 20% or less impervious cover.
- The site will be used for low density single-family residential development but has more than 20% impervious cover.
- The site will not be used for low density single-family residential development.

51. The executive director may waive the requirement for other permanent BMPs for multi-family residential developments, schools, or small business sites where 20% or less impervious cover is used at the site. This exemption from permanent BMPs must be recorded in the county deed records, with a notice that if the percent impervious cover increases above 20% or land use changes, the exemption for the whole site as described in the property boundaries required by 30 TAC §213.4(g) (relating to Application Processing and Approval), may no longer apply and the property owner must notify the appropriate regional office of these changes.

- Attachment I - 20% or Less Impervious Cover Waiver. The site will be used for multi-family residential developments, schools, or small business sites and has 20% or less impervious cover. A request to waive the requirements for other permanent BMPs and measures is attached.
- The site will be used for multi-family residential developments, schools, or small business sites but has more than 20% impervious cover.
- The site will not be used for multi-family residential developments, schools, or small business sites.

52. Attachment J - BMPs for Upgradient Stormwater.

- A description of the BMPs and measures that will be used to prevent pollution of surface water, groundwater, or stormwater that originates upgradient from the site and flows across the site is attached.
- No surface water, groundwater or stormwater originates upgradient from the site and flows across the site, and an explanation is attached.
- Permanent BMPs or measures are not required to prevent pollution of surface water, groundwater, or stormwater that originates upgradient from the site and flows across the site, and an explanation is attached.

53. Attachment K - BMPs for On-site Stormwater.

- A description of the BMPs and measures that will be used to prevent pollution of surface water or groundwater that originates on-site or flows off the site, including pollution caused by contaminated stormwater runoff from the site is attached.
- Permanent BMPs or measures are not required to prevent pollution of surface water or groundwater that originates on-site or flows off the site, including pollution caused by contaminated stormwater runoff, and an explanation is attached.

54. Attachment L - BMPs for Surface Streams. A description of the BMPs and measures that prevent pollutants from entering surface streams is attached.

N/A

55. Attachment M - Construction Plans. Construction plans and design calculations for the proposed permanent BMPs and measures have been prepared by or under the direct supervision of a Texas Licensed Professional Engineer, and are signed, sealed, and dated. Construction plans for the proposed permanent BMPs and measures are attached and include: Design calculations, TCEQ Construction Notes, all proposed structural plans and specifications, and appropriate details.

N/A

56. Attachment N - Inspection, Maintenance, Repair and Retrofit Plan. A site and BMP specific plan for the inspection, maintenance, repair, and, if necessary, retrofit of the permanent BMPs and measures is attached. The plan fulfills all of the following:

- Prepared and certified by the engineer designing the permanent BMPs and measures
- Signed by the owner or responsible party
- Outlines specific procedures for documenting inspections, maintenance, repairs, and, if necessary, retrofit.
- Contains a discussion of record keeping procedures

N/A

57. Attachment O - Pilot-Scale Field Testing Plan. Pilot studies for BMPs that are not recognized by the Executive Director require prior approval from the TCEQ. A plan for pilot-scale field testing is attached.

N/A

58. Attachment P - Measures for Minimizing Surface Stream Contamination. A description of the measures that will be used to avoid or minimize surface stream contamination and changes in the way in which water enters a stream as a result of the construction and development is attached. The measures address increased stream flashing, the creation of stronger flows and in-stream velocities, and other in-stream effects caused by the regulated activity, which increase erosion that result in water quality degradation.

N/A

Responsibility for Maintenance of Permanent BMPs and Measures after Construction is Complete.

59. The applicant is responsible for maintaining the permanent BMPs after construction until such time as the maintenance obligation is either assumed in writing by another entity having ownership or control of the property (such as without limitation, an owner's association, a new property owner or lessee, a district, or municipality) or the ownership of the property is transferred to the entity. Such entity shall then be

responsible for maintenance until another entity assumes such obligations in writing or ownership is transferred.

60. A copy of the transfer of responsibility must be filed with the executive director at the appropriate regional office within 30 days of the transfer if the site is for use as a multiple single-family residential development, a multi-family residential development, or a non-residential development such as commercial, industrial, institutional, schools, and other sites where regulated activities occur.

Administrative Information

61. Submit one (1) original and one (1) copy of the application, plus additional copies as needed for each affected incorporated city, groundwater conservation district, and county in which the project will be located. The TCEQ will distribute the additional copies to these jurisdictions.
62. Any modification of this Contributing Zone Plan may require TCEQ review and Executive Director approval prior to construction, and may require submission of a revised application, with appropriate fees.
63. The site description, controls, maintenance, and inspection requirements for the storm water pollution prevention plan (SWPPP) developed under the EPA NPDES general permits for stormwater discharges have been submitted to fulfill paragraphs 30 TAC §213.24(1-5) of the technical report. All requirements of 30 TAC §213.24(1-5) have been met by the SWPPP document.
- The Temporary Stormwater Section (TCEQ-0602) is included with the application.

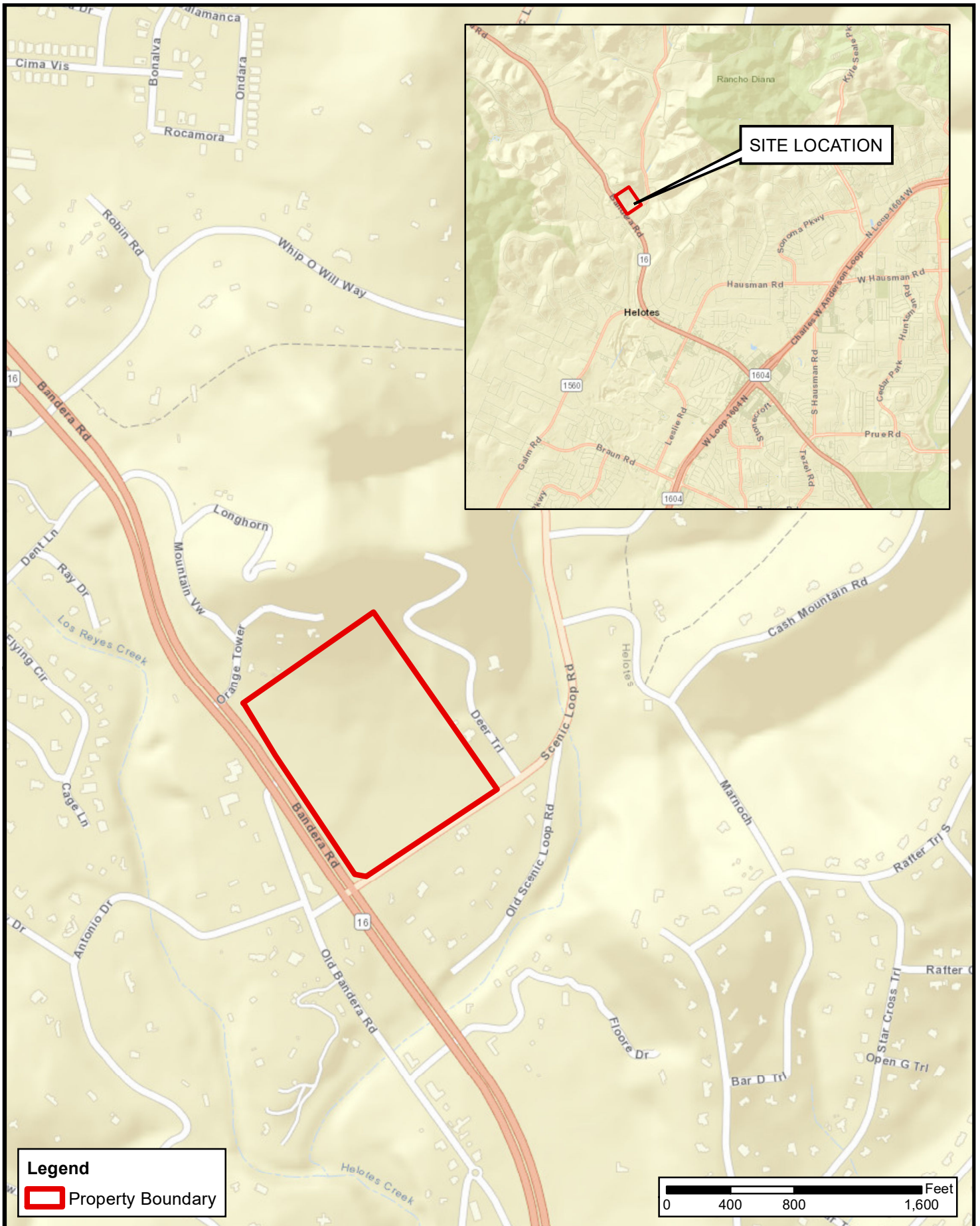

Legend

 Property Boundary

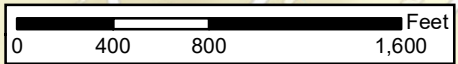

SHEET 1 OF 1 SHEETS	DATE:	03/29/2024
	DESIGN:	ARG
	DRAWN:	ARG
	CHECKED:	MGM
	KHA NO.:	069401104

**LOCATION MAP
ATTACHMENT A**

CZP
BANDERA
RANCH
HELOTES
BEXAR COUNTY, TEXAS



Kimley»Horn

This product is for informational purposes and may not have been prepared for or be suitable for legal, engineering, or surveying purposes. It does not represent an on-the-ground survey and represents only the approximate relative location of property boundaries.

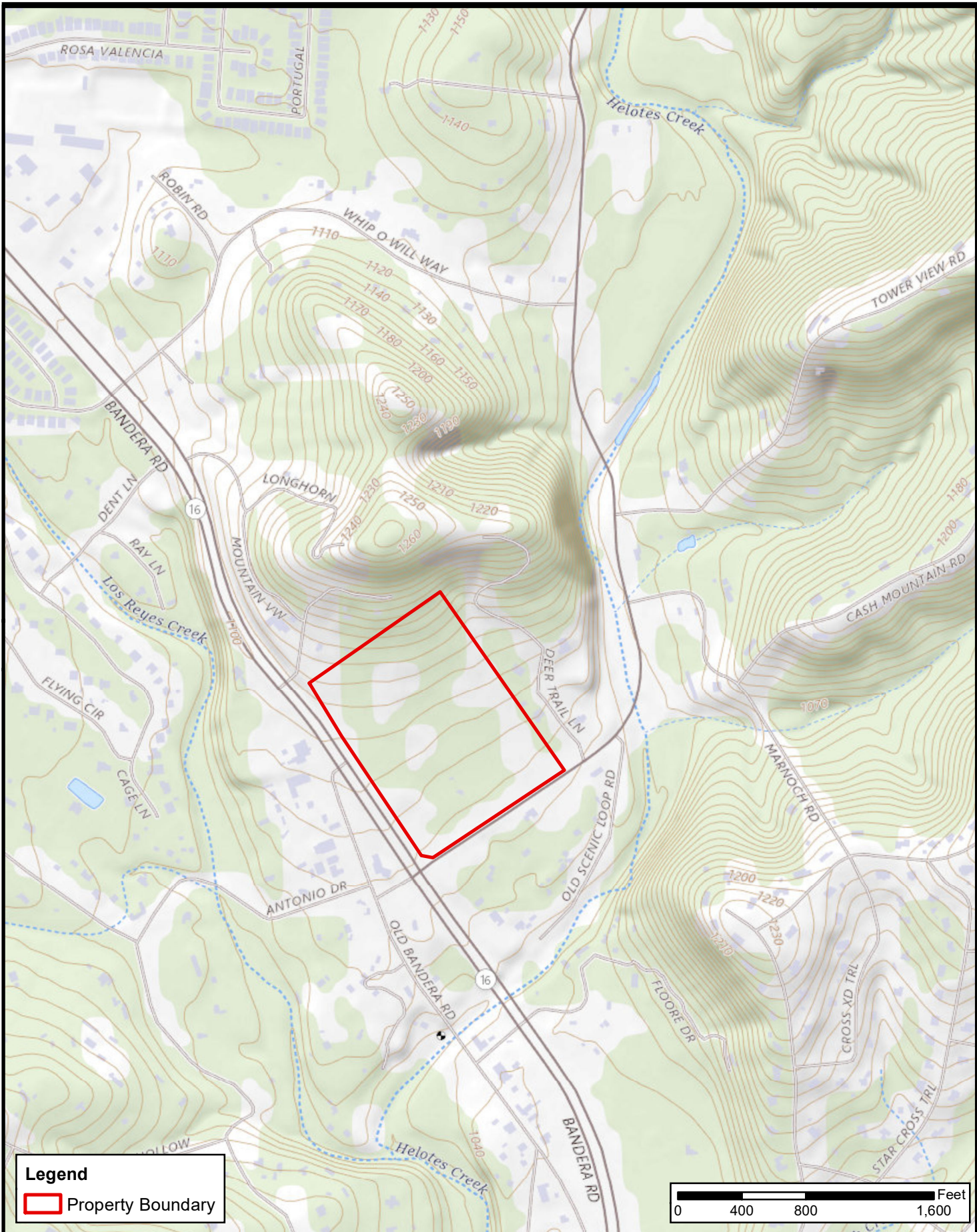

Legend

Property Boundary



1	SHEET	DATE: 03/29/2024
		DESIGN: ARG
		DRAWN: ARG
		CHECKED: MGM
	OF 1 SHEETS	KHA NO.: 069401104

USGS Topographic Map
 QUAD NAME: HELOTES
 ATTACHMENT B

CZP
 BANDERA
 RANCH
 HELOTES
 BEXAR COUNTY, TEXAS



Kimley»Horn

This product is for informational purposes and may not have been prepared for or be suitable for legal, engineering, or surveying purposes. It does not represent an on-the-ground survey and represents only the approximate relative location of property boundaries.

ATTACHMENT C – PROJECT NARRATIVE

The Bandera Ranch Development site is located at 15030 Bandera Road in the City of Helotes, Bexar County, Texas and is currently within a Planned Unit Development (PUD).

The Bandera Ranch plat demonstrates Lot 1, 22.98 acres, that will be proposed as a single-family for rent with +/- 230 proposed dwelling units. Lot 2, 8.483 acres, will be proposed for commercial use. The extent of work for the entire property is limited to grading and installation of proposed structures, pavement, and private infrastructure. Disturbance is approximately 27.693 acres for Lot 1, and 8.483 acres in Lot 2. The +/- 31.463-acre site will propose approximately 50% of impervious cover (+/- 15.70 acres), including +/- 5.10 acres of building roofs and +/- 10.60 acres of parking and other paved surfaces. Lot 2 will consist of commercial buildings such as a restaurant, office, and retail stores, totaling to ±33,445 SF of building roofs. To treat the stormwater runoff, two batch detention basins will be provided as a permanent BMPs. The site's existing condition is undeveloped but currently has two existing sheds that will be demolished.

ATTACHMENT D – FACTORS AFFECTING SURFACE WATER QUALITY

Surface water quality can be affected by disturbance during construction and by development after construction. Soil disturbance from clearing, grubbing, and cut/fill operations can lead to the discharge of sediment unless adequate temporary erosion control measures are in place. For this project, the use of sedimentation basins, silt fences, inlet protection, and rock berms will prevent sediment from leaving the site. Siltation collected by the control measures will be cleaned from fences, berms, etc. on a routine schedule.

During construction, surface water quality may also be affected by a spill of hydrocarbons or other hazardous substances used in construction. The most likely instances of a spill of hydrocarbons and hazardous substance areas include:

1. Refueling construction equipment
2. Performing operator-level maintenance, including adding petroleum, oils, or lubricants.
3. Unscheduled or emergency repairs, such as hydraulic fluid leaks.

Every effort will be taken to be cautious and prevent spills. In the event of a fuel or hazardous substance spill, the contractor is required to clean up the spill and notify the TCEQ. During business hours, report spills to TCEQ's San Antonio Regional Office at (210) 490-3096. After business hours call 1-800-832-8224.

After construction is complete, impervious cover for the tract of land is the major cause for water quality degradation. Impervious cover includes building, parking, pavement and driveways. Oil and fuel discharges from vehicles is anticipated. The batch detention basin/water quality ponds and are proposed to treat the first flush of runoff from the respective drainage area as indicated on the TCEQ Site Plan included in this application.

ATTACHMENT E – VOLUME AND CHARACTER OF STORMWATER

The construction site is located 15030 Bandera Road Helotes, Texas. Currently, there is a highpoint in the north corner of the site causing site to sheet flow to the southeast area. The elevation on the construction site ranges from 1055 feet to 1165 feet. Both the existing and proposed contours are provided on the TCEQ Site Plan included in Attachment M.

The +/-31.463-acre site will include 50% impervious cover. The remaining pervious portions of the site will consist of landscape and natural areas. Runoff from the developed areas will travel as sheet flow and shallow concentrated flow across both pervious and impervious area to the batch detention ponds. The locations of the detention/water quality ponds are shown on the TCEQ Site Plan attached.

ATTACHMENT F – SUITABILITY LETTER FROM AUTHORIZED AGENT

An onsite sewage facility will **not** be used to treat and dispose of wastewater. Wastewater from the proposed development will outfall into the Leon Creek collection and treatment system. Not applicable.

ATTACHMENT G- Alternative Secondary Containment Methods

(Not Applicable)

**ATTACHMENT H – ALTERNATIVE SECONDARY CONTAINMENT
STRUCTURE DRAWINGS**

(Not applicable)

ATTACHMENT I – 20% or Less Impervious Cover Waiver

(Not applicable)

ATTACHMENT J – BMP's for Upgradient Storm Water

(Not Applicable)

ATTACHMENT K – BMP's For On-Site Storm Water

A batch detention basin will be utilized as the permanent treatment system on this site for each respective drainage area. Stormwater runoff from impervious areas will be collected by an underground storm sewer system and routed to the provided ponds to provide at least 75% removal of the increase in Total Suspended Solids. Calculations for TSS Removals are provided on the following page.

Additional information is provided for cells with a red triangle in the upper right corner. Place the cursor over the cell. Text shown in blue indicate location of instructions in the Technical Guidance Manual - RG-348.

Characters shown in red are data entry fields.

Characters shown in black (Bold) are calculated fields. Changes to these fields will remove the equations used in the spreadsheet

1. The Required Load Reduction for the total project:

Calculations from RG-348

Pages 3-27 to 3-30

Page 3-29 Equation 3.3: $L_M = 27.2(A_N \times P)$

where:

$L_{M \text{ TOTAL PROJECT}}$ = Required TSS removal resulting from the proposed development = 80% of increased k
 A_N = Net increase in impervious area for the project
 P = Average annual precipitation, inches

Site Data: Determine Required Load Removal Based on the Entire Project

County =	Bexar	
Total project area included in plan *	31.46	acres
Predevelopment impervious area within the limits of the plan *	0.00	acres
Total post-development impervious area within the limits of the plan *	15.70	acres
Total post-development impervious cover fraction *	0.50	
P =	30	inches

$L_{M \text{ TOTAL PROJECT}} = 12811$ lbs.

* The values entered in these fields should be for the total project area.

Number of drainage basins / outfalls areas leaving the plan area = **1**

2. Drainage Basin Parameters (This information should be provided for each basin):

Drainage Basin/Outfall Area No. = **POND A**

Total drainage basin/outfall area =	18.98	acres
Predevelopment impervious area within drainage basin/outfall area =	0.00	acres
Post-development impervious area within drainage basin/outfall area =	10.44	acres
Post-development impervious fraction within drainage basin/outfall area =	0.55	
$L_{M \text{ THIS BASIN}}$ =	8519	lbs.

3. Indicate the proposed BMP Code for this basin.

Proposed BMP = **Batch Detention**
 Removal efficiency = **91** percent

- Aqualogic Cartridge Filter
- Batch Detention
- Bioretention
- Contech StormFilter
- Constructed Wetland
- Extended Detention
- Grassy Swale
- Retention / Irrigation
- Sand Filter
- Stormceptor
- Vegetated Filter Strips
- Vortechs
- Wet Basin
- Wet Vault

4. Calculate Maximum TSS Load Removed (L_R) for this Drainage Basin by the selected BMP Type.

RG-348 Page 3-33 Equation 3.7: $L_R = (\text{BMP efficiency}) \times P \times (A_i \times 34.6 + A_p \times 0.54)$

where:

A_C = Total On-Site drainage area in the BMP catchment area
 A_i = Impervious area proposed in the BMP catchment area
 A_p = Pervious area remaining in the BMP catchment area
 L_R = TSS Load removed from this catchment area by the proposed BMP

$A_C = 18.98$ acres
 $A_I = 10.44$ acres
 $A_P = 8.54$ acres
 $L_R = 9987$ lbs

5. Calculate Fraction of Annual Runoff to Treat the drainage basin / outfall area

Desired $L_{M \text{ THIS BASIN}} = 9100$ lbs.

$F = 0.91$

6. Calculate Capture Volume required by the BMP Type for this drainage basin / outfall area.

Calculations from RG-348

Pages 3-34 to 3-36

Rainfall Depth = 1.80 inches
 Post Development Runoff Coefficient = 0.39
 On-site Water Quality Volume = 47966 cubic feet

Calculations from RG-348 Pages 3-36 to 3-37

Off-site area draining to BMP = 0.00 acres
 Off-site Impervious cover draining to BMP = 0.00 acres
 Impervious fraction of off-site area = 0
 Off-site Runoff Coefficient = 0.00
 Off-site Water Quality Volume = 0 cubic feet

Storage for Sediment = 9593

Total Capture Volume (required water quality volume(s) x 1.20) = 57559 cubic feet

The following sections are used to calculate the required water quality volume(s) for the selected BMP. The values for BMP Types not selected in cell C45 will show NA.

7. Retention/Irrigation System

Designed as Required in RG-348

Pages 3-42 to 3-46

Required Water Quality Volume for retention basin = NA cubic feet

Irrigation Area Calculations:

Soil infiltration/permeability rate = 0.1 in/hr Enter determined permeability rate or assumed value
 Irrigation area = NA square feet
 Irrigation area = NA acres

8. Extended Detention Basin System

Designed as Required in RG-348

Pages 3-46 to 3-51

Required Water Quality Volume for extended detention basin = 57559 cubic feet



03/29/2024

Additional information is provided for cells with a red triangle in the upper right corner. Place the cursor over the cell.

Text shown in blue indicate location of instructions in the Technical Guidance Manual - RG-348.

Characters shown in red are data entry fields.

Characters shown in black (Bold) are calculated fields. Changes to these fields will remove the equations used in the spreadsheet

1. The Required Load Reduction for the total project:

Calculations from RG-348

Pages 3-27 to 3-30

Page 3-29 Equation 3.3: $L_M = 27.2(A_N \times P)$

where:

$L_{M \text{ TOTAL PROJECT}}$ = Required TSS removal resulting from the proposed development = 80% of increased k

A_N = Net increase in impervious area for the project

P = Average annual precipitation, inches

Site Data: Determine Required Load Removal Based on the Entire Project

County =	Bexar	
Total project area included in plan *	31.46	acres
Predevelopment impervious area within the limits of the plan *	0.00	acres
Total post-development impervious area within the limits of the plan *	15.70	acres
Total post-development impervious cover fraction *	0.50	
P =	30	inches

$L_{M \text{ TOTAL PROJECT}} = 12811$ lbs.

* The values entered in these fields should be for the total project area.

Number of drainage basins / outfalls areas leaving the plan area = **1**

2. Drainage Basin Parameters (This information should be provided for each basin):

Drainage Basin/Outfall Area No. = **POND B**

Total drainage basin/outfall area =	9.47	acres
Predevelopment impervious area within drainage basin/outfall area =	0.00	acres
Post-development impervious area within drainage basin/outfall area =	5.25	acres
Post-development impervious fraction within drainage basin/outfall area =	0.55	
$L_{M \text{ THIS BASIN}}$ =	4284	lbs.

3. Indicate the proposed BMP Code for this basin.

Proposed BMP = **Batch Detention**
Removal efficiency = **91** percent

- Aqualogic Cartridge Filter
- Bioretention
- Contech StormFilter
- Constructed Wetland
- Extended Detention
- Grassy Swale
- Retention / Irrigation
- Sand Filter
- Stormceptor
- Vegetated Filter Strips
- Vortechs
- Wet Basin
- Wet Vault

4. Calculate Maximum TSS Load Removed (L_R) for this Drainage Basin by the selected BMP Type.

RG-348 Page 3-33 Equation 3.7: $L_R = (\text{BMP efficiency}) \times P \times (A_I \times 34.6 + A_P \times 0.54)$

where:

A_C = Total On-Site drainage area in the BMP catchment area

A_I = Impervious area proposed in the BMP catchment area

A_P = Pervious area remaining in the BMP catchment area

L_R = TSS Load removed from this catchment area by the proposed BMP

A_C = 9.47 acres
A_I = 5.25 acres
A_P = 4.22 acres
L_R = 5021 lbs

5. Calculate Fraction of Annual Runoff to Treat the drainage basin / outfall area

Desired L_{M THIS BASIN} = 3711 lbs.
F = 0.74

6. Calculate Capture Volume required by the BMP Type for this drainage basin / outfall area.

Calculations from RG-348

Pages 3-34 to 3-36

Rainfall Depth = 0.89 inches
Post Development Runoff Coefficient = 0.39
On-site Water Quality Volume = 11890 cubic feet

Calculations from RG-348 Pages 3-36 to 3-37

Off-site area draining to BMP = 0.00 acres
Off-site Impervious cover draining to BMP = 0.00 acres
Impervious fraction of off-site area = 0
Off-site Runoff Coefficient = 0.00
Off-site Water Quality Volume = 0 cubic feet

Storage for Sediment = 2378

Total Capture Volume (required water quality volume(s) x 1.20) = 14268 cubic feet

The following sections are used to calculate the required water quality volume(s) for the selected BMP.
The values for BMP Types not selected in cell C45 will show NA.

7. Retention/Irrigation System

Designed as Required in RG-348

Pages 3-42 to 3-46

Required Water Quality Volume for retention basin = NA cubic feet

Irrigation Area Calculations:

Soil infiltration/permeability rate = 0.1 in/hr Enter determined permeability rate or assumed value
Irrigation area = NA square feet
NA acres

8. Extended Detention Basin System

Designed as Required in RG-348

Pages 3-46 to 3-51

Required Water Quality Volume for extended detention basin = 14268 cubic feet



03/29/2024

ATTACHMENT L – BMPs For Surface Streams

(Not Applicable)

ATTACHMENT M - CONSTRUCTION PLANS

Calculations for the load removal requirements for the project and the load removal provided by the permanent detention/water quality ponds are provided in Attachment K of this report. The calculations have been signed and sealed by a professional engineer licensed in the state of Texas. The load removal requirements are derived from the equations from the technical guidance manual based on the project area and impervious cover. All stormwater runoff from impervious areas will be treated by the proposed permanent detention/water quality ponds to provide the removal of at least 75% of the increase in Total Suspended Solids. Provided within the calculations is a summary of the amount of pollutant load required to be removed from the drainage areas and the amount of removal provided by the permanent detention/water quality ponds.

Construction plans, details, specifications, calculations, and construction notes are provided on the following pages.

Project: Bander Ranch, March 09, 2024, 09:10:12am, K:\SMA_Civil\66549104 - Bander Ranch (BTR) (SMA) (Sheet) C:\DWG\66549104.dwg
 This document, together with the concepts and designs presented herein, is intended only for the specific purpose and client for which it was prepared. Reuse of and improper reliance on this document without written authorization and adaptation by Kimley-Horn and Associates, Inc. shall be without liability to Kimley-Horn and Associates, Inc.

PEAK FLOW CALCULATIONS											
Basin	Tc (min)	A (ac)	C	I-1 (in/hr)	I-5 (in/hr)	I-25 (in/hr)	I-100 (in/hr)	Q-1 (cfs)	Q-5 (cfs)	Q-25 (cfs)	Q-100 (cfs)
PR-A	14.6	18.98	0.76	3.66	5.40	7.51	9.42	52.87	78.10	108.68	136.25
BY-A	14.4	3.64	0.52	3.68	5.44	7.57	9.49	6.96	10.29	14.32	17.96
BY-B	12.3	3.16	0.52	3.93	5.85	8.15	10.28	6.45	9.61	13.40	16.89
BY-C	12.7	1.45	0.52	3.88	5.78	8.05	10.15	2.93	4.36	6.07	7.65
PR-B1	7.7	0.98	0.52	4.64	6.95	9.71	12.30	2.36	3.54	4.95	6.27

LEGEND

- EXISTING CONTOURS
- PROPOSED CONTOURS
- DRAINAGE BOUNDARY
- DRAINAGE AREA NAME
- DRAINAGE AREA ACREAGE
- FLOW PATH
- DISCHARGE POINT

GRAPHIC SCALE IN FEET

0 30 60 120

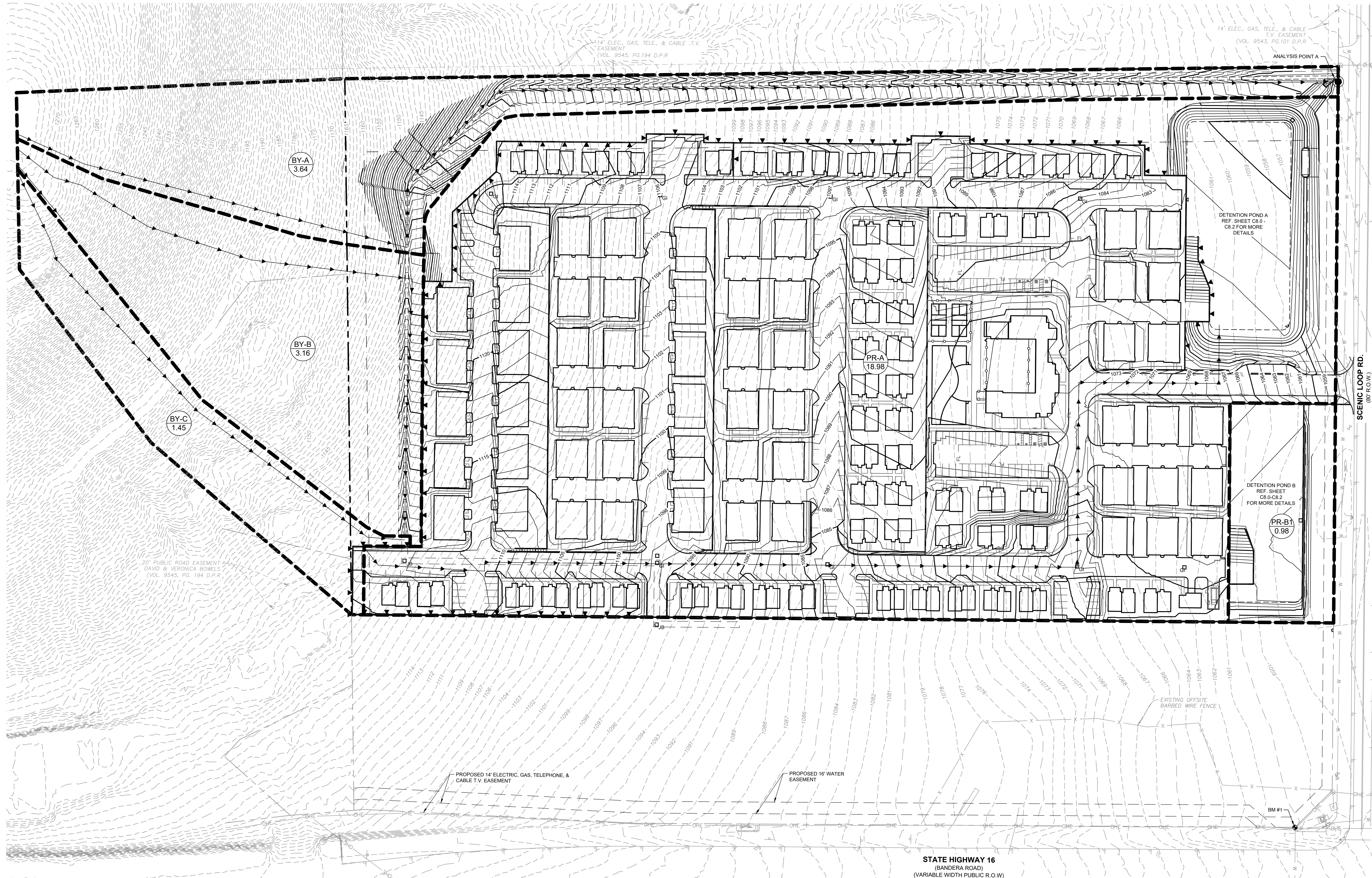

Kimley-Horn	© 2024 KIMLEY-HORN AND ASSOCIATES, INC. 10101 REFINON PLACE, SUITE 400, SAN ANTONIO, TX 78216 WWW.KIMLEY-HORN.COM TBE FIRM NO. 928			
KHA PROJECT 069401104 DATE 3/29/2024 SCALE AS SHOWN DESIGNED BY ARC DRAWN BY ARC CHECKED BY MGM	PROPOSED DRAINAGE AREA MAP			
BANDERA RANCH PREPARED FOR PARAVEL CAPITAL	SHEET NUMBER C6.1			
HELOTES				TX
REVISIONS	No.	BY	DATE	BY

Prepared by: Kimley-Horn and Associates, Inc. March 28, 2024, 10:21:48am. K:\SWA_Site\36840104 - Banderas Ranch (Site Plan)\CADD\DWG\16-DRAINAGE\16-DRAINAGE.dwg
 This document, together with the concepts and designs presented herein, is intended only for the specific purpose and client for which it was prepared. Reuse of and improper reliance on this document without written authorization and adaptation by Kimley-Horn and Associates, Inc. shall be without liability to Kimley-Horn and Associates, Inc.

PEAK FLOW CALCULATIONS											
Basin	Tc (min)	A (ac)	C	I-1 (in/hr)	I-5 (in/hr)	I-25 (in/hr)	I-100 (in/hr)	Q-1 (cfs)	Q-5 (cfs)	Q-25 (cfs)	Q-100 (cfs)
PR-A	14.6	18.98	0.76	3.66	5.40	7.51	9.42	52.87	78.10	108.68	136.25
PR-B	14.4	9.47	0.87	3.67	5.43	7.56	9.48	30.32	44.82	62.37	78.23
BY-A	14.4	3.64	0.52	3.68	5.44	7.57	9.49	6.96	10.29	14.32	17.96
BY-B	12.3	3.16	0.52	3.93	5.85	8.15	10.28	6.45	9.61	13.40	16.89
BY-C	12.7	1.45	0.52	3.88	5.78	8.05	10.15	2.93	4.36	6.07	7.65

Discharge Results			
POND A			
EXISTING FLOW	Q-5	Q-25	Q-100
68.56	95.42	119.69	
BYPASS			
18.30	25.44	31.83	
ALLOWABLE RELEASE			
50.27	69.98	87.86	
PROPOSED RELEASE			
40.17	58.11	74.45	
POND B			
EXISTING FLOW	Q-5	Q-25	Q-100
17.76	24.67	30.81	
BYPASS			
0.00	0.00	0.00	
ALLOWABLE RELEASE			
17.76	24.67	30.81	
PROPOSED RELEASE			
15.22	22.62	29.20	

LEGEND	
	EXISTING CONTOURS
	PROPOSED CONTOURS
	DRAINAGE BOUNDARY
	DRAINAGE AREA NAME
	DRAINAGE AREA ACREAGE
	FLOW PATH
	DISCHARGE POINT

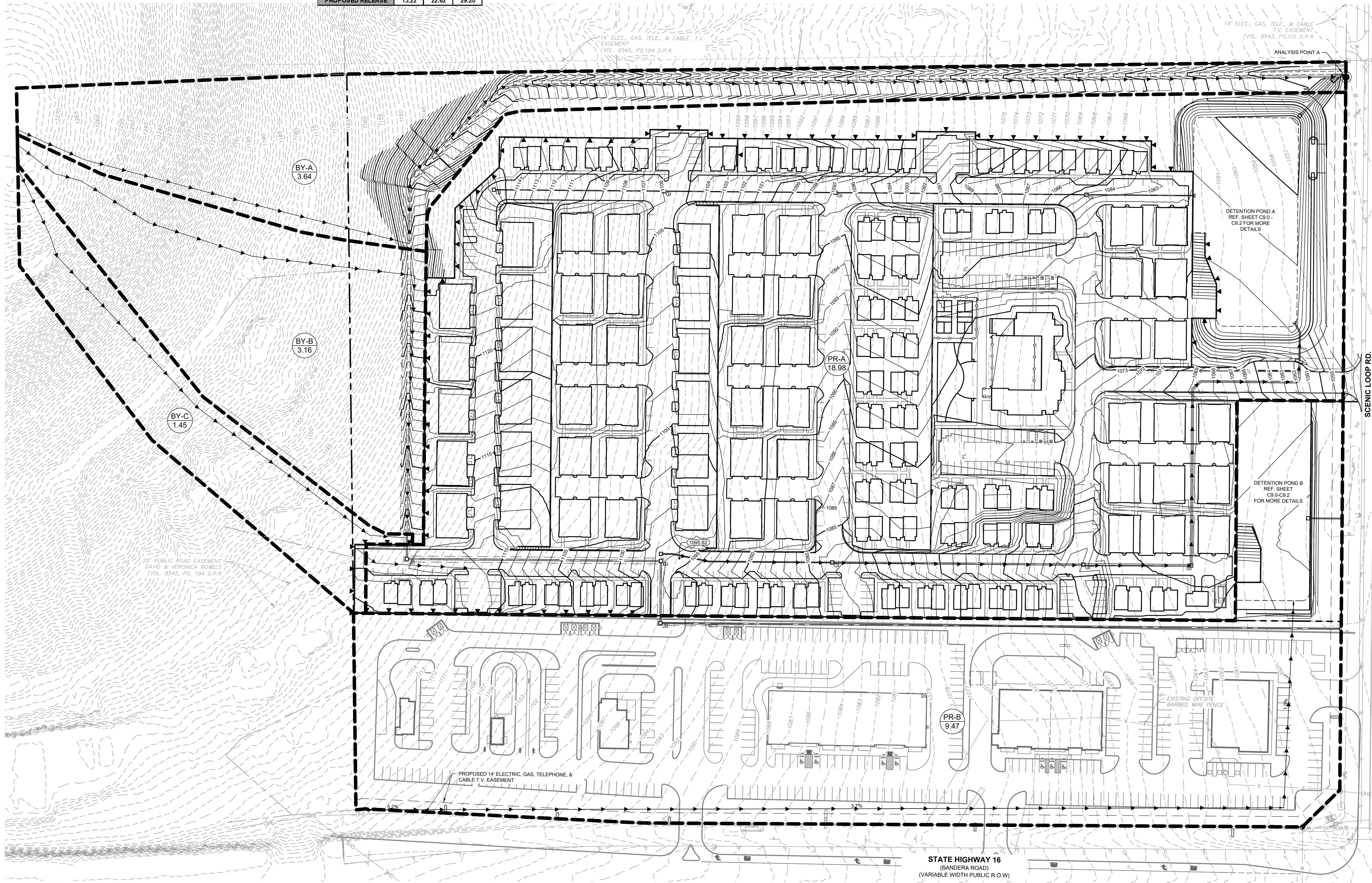
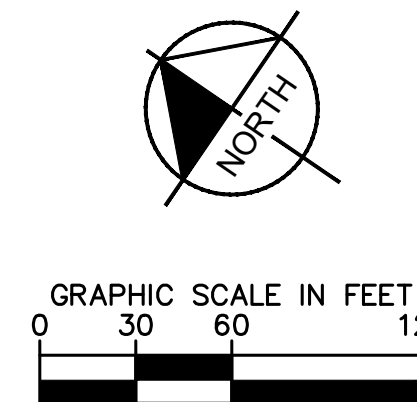

Kimley-Horn
 © 2024 KIMLEY-HORN AND ASSOCIATES, INC.
 10101 REIMUN PLACE, SUITE 400, SAN ANTONIO, TX 78216
 WWW.KIMLEY-HORN.COM | TBE FIRM NO. 928

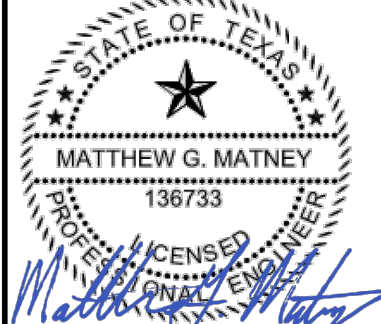

KHA PROJECT: 069401104
 DATE: 3/29/2024
 SCALE: AS SHOWN
 DESIGNED BY: ARC
 DRAWN BY: ARC
 CHECKED BY: MGM

ULTIMATE PROPOSED DRAINAGE AREA MAP

BANDERA RANCH
 PREPARED FOR
PARAVEL CAPITAL

Project: Bander Ranch, March 29, 2024, 11:28:16am, K:\SMA_Civil\2024\Bander Ranch\Drawings\Storm\Storm\SECTION_09.C9.0.dwg
 This document, together with the concepts and designs presented herein, is an instrument of service, as an instrument of service, and shall be without liability to Kimley-Horn and Associates, Inc.

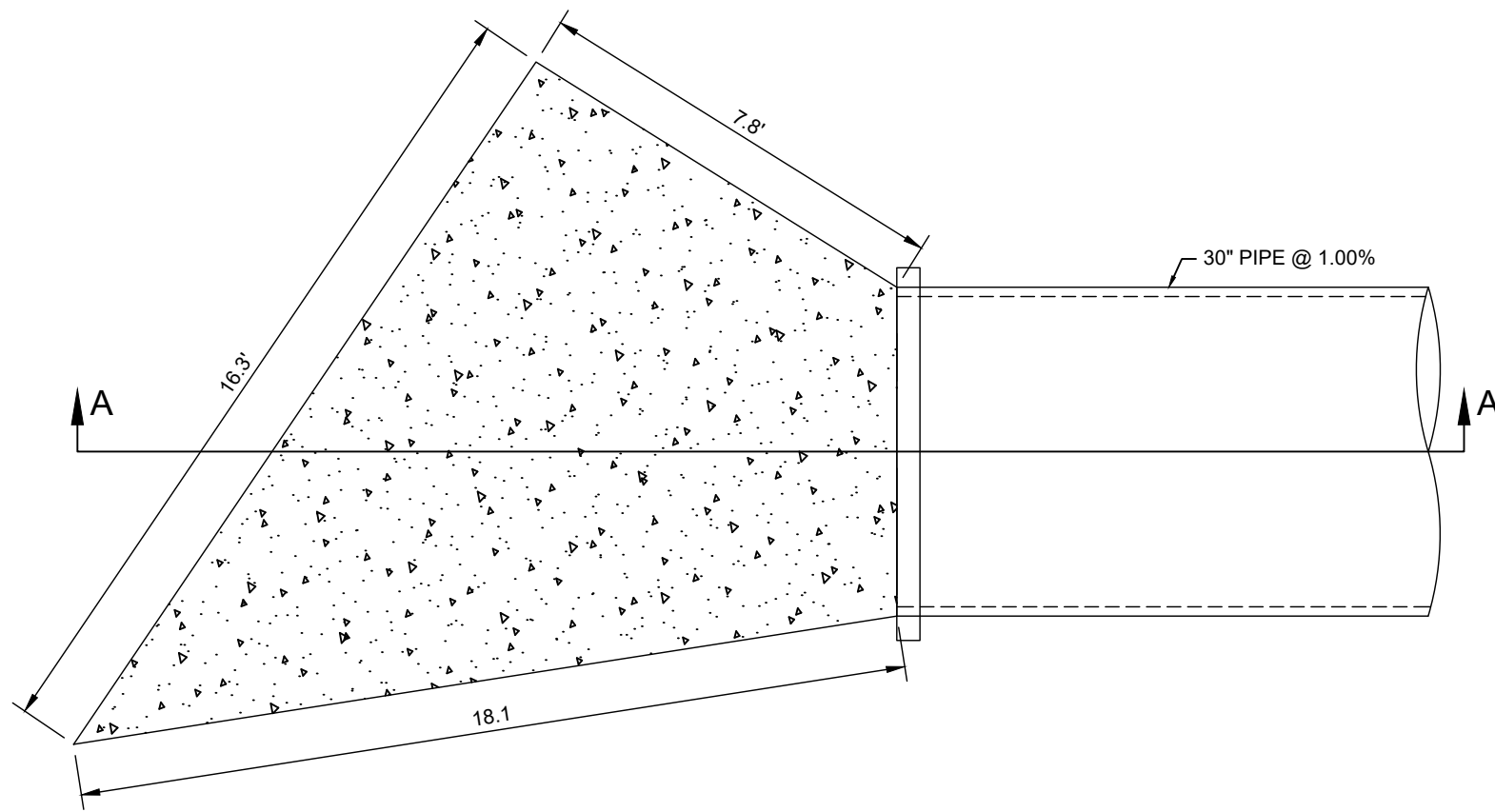
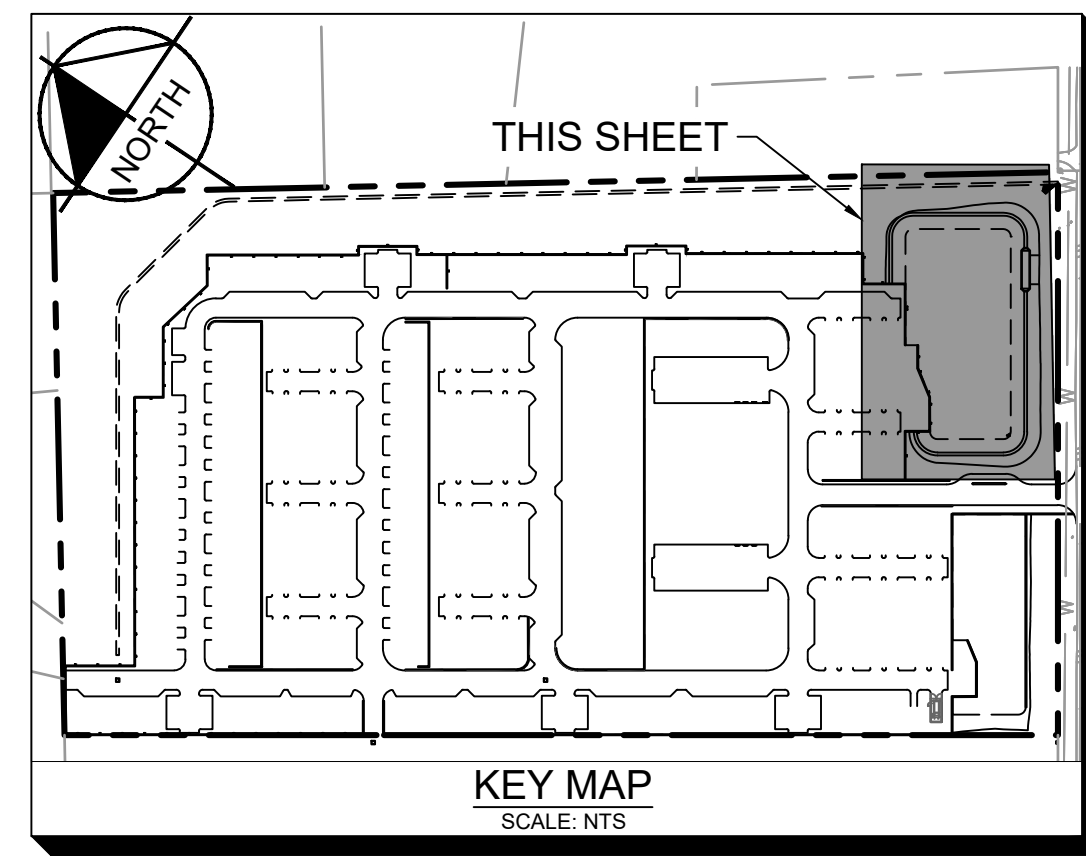

POND A STAGE STORAGE TABLE

STAGE ELEVATION (FT.)	AREA (SQ. FT.)	INC. VOL (CU. FT.)	CUM. VOL (CU. FT.)
1054.00	54	-	-
1055.00	6,400	3,227	3,227
1056.00	20,732	13,566	16,793
1057.00	34,546	27,639	44,432
1057.40	37,190	14,347	58,779
1058.00	41,155	37,850	82,282
1059.00	43,171	42,163	124,445
1060.00	45,243	44,207	168,652

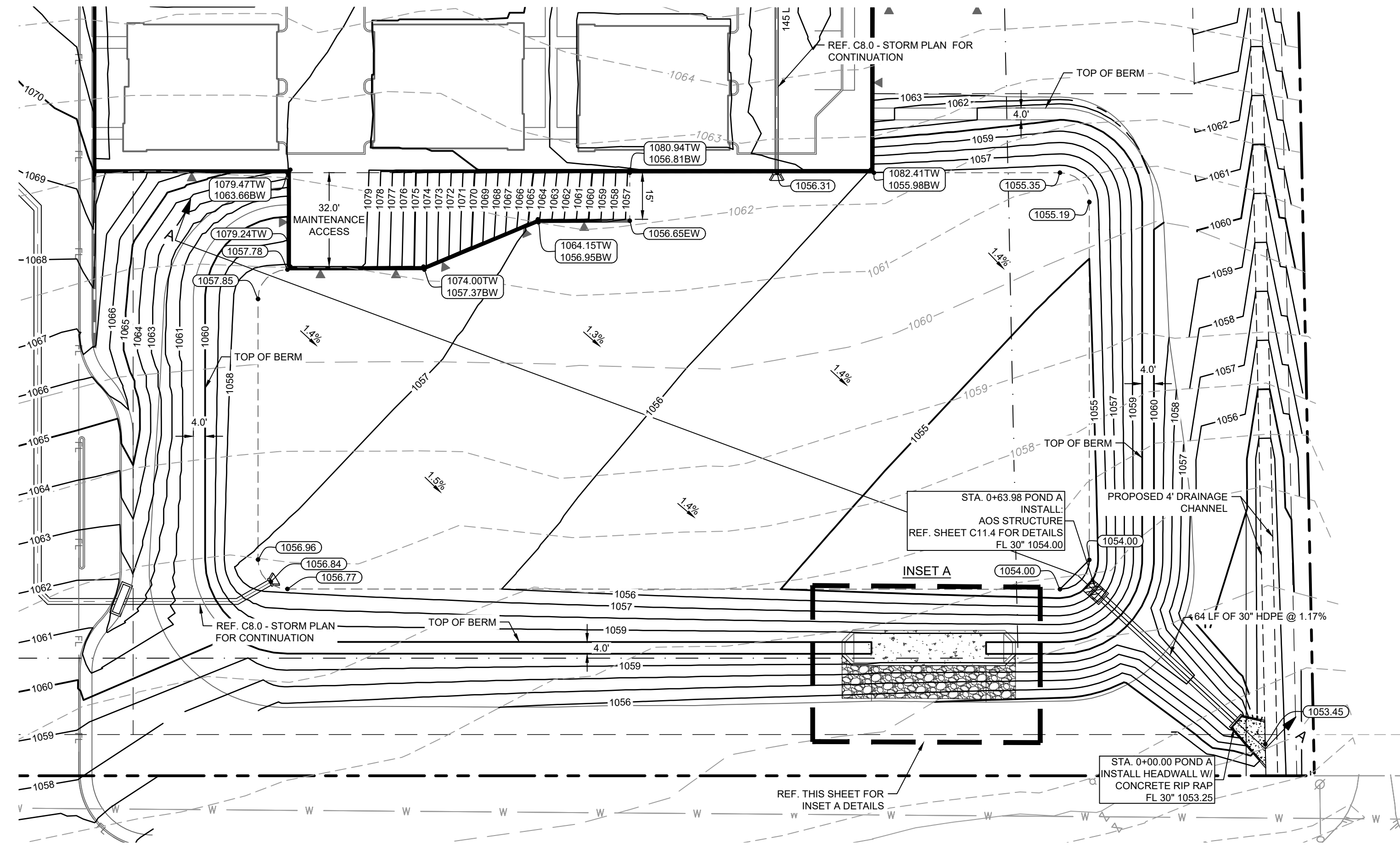
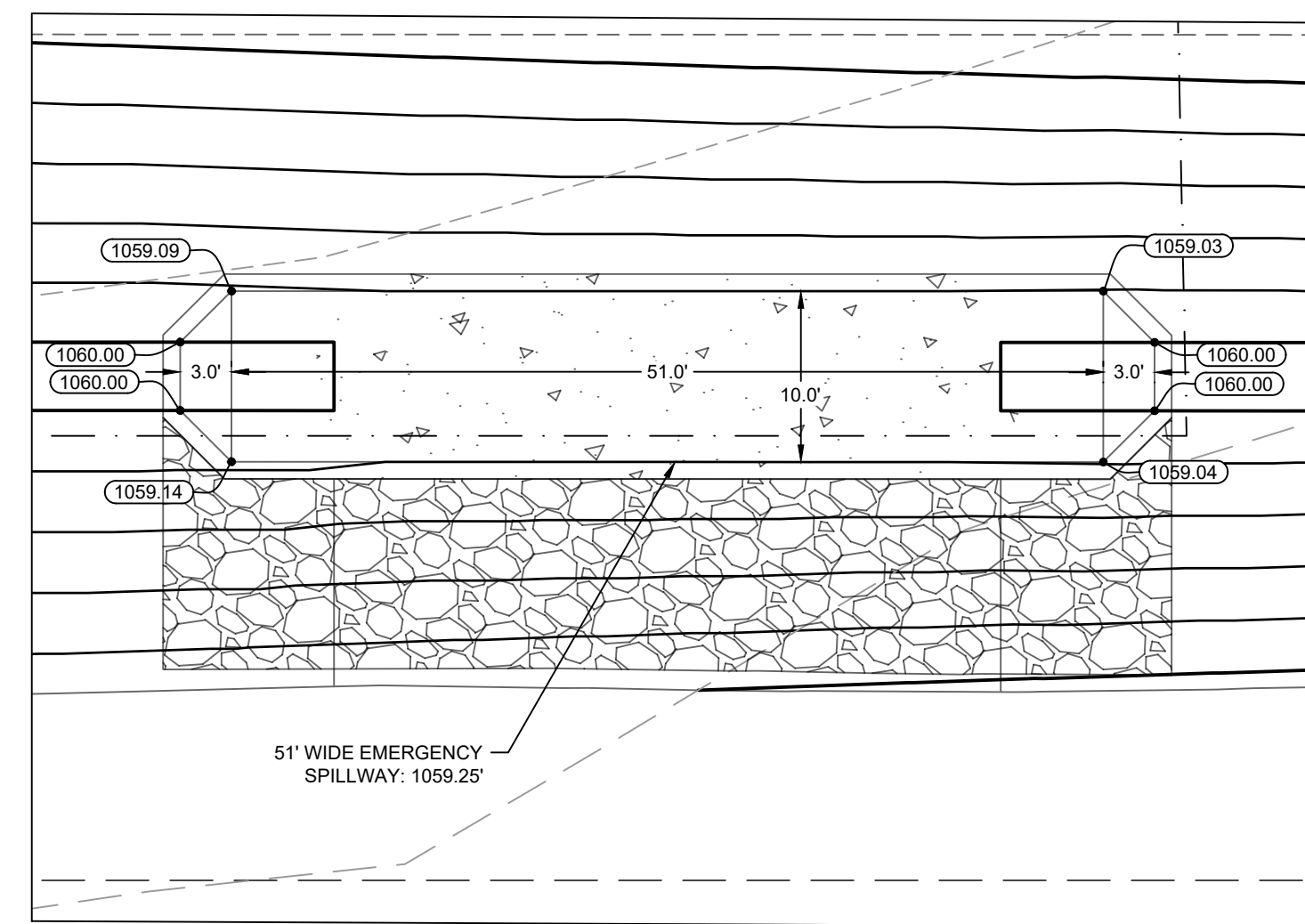

LEGEND

- XXXX.XX PROPOSED SPOT ELEVATION
- PROPOSED CONTOURS
- - - EXISTING CONTOURS
- - - PROPOSED SWALE
- ▲-▲-▲ PROPOSED RETAINING WALL (TRIANGLE INDICATES FACE OF WALL)
- ▒ CONCRETE RIP RAP

- STORM NOTES**
- ALL DIMENSIONS ARE TO CENTERLINE OF PIPE UNLESS NOTED OTHERWISE.
 - REFERENCE SAWS CONSTRUCTION STANDARDS FOR PIPE MATERIAL REQUIREMENTS.
 - REFERENCE SHEET C12.3 FOR STORM SEWER DETAILS.
 - CONTRACTOR TO FIELD VERIFY LOCATION OF ALL UTILITIES PRIOR TO CONSTRUCTION. CONTACT ENGINEER IF FIELD CONDITIONS VARY.

WATER QUALITY BASIN DETAILS

ITEM	QUANTITY
WQ VOLUME REQUIRED	57,559 CF
WQ VOLUME PROVIDED	58,779 CF
WQ STORAGE DEPTH	3.40 FT

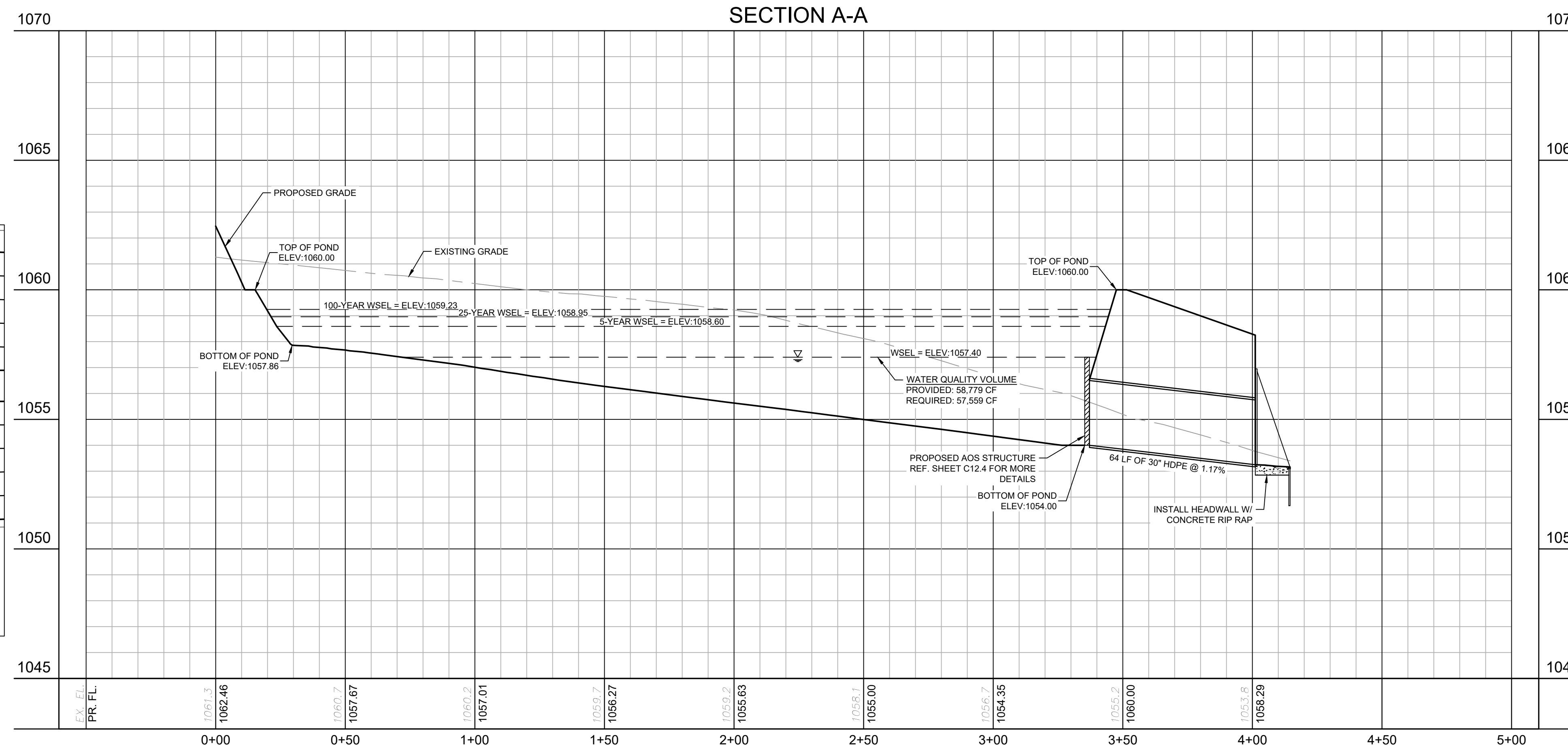

BENCHMARK LIST

BMW 1	3" IRON ROD FOUND WITH YELLOW CAP MARKED 'PAPE-DAWSON' AT A SOUTHWEST CORNER OF SAID 31.460 ACRE TRACT ELEVATION: 1060.00'
-------	--

CAUTION!
EXISTING UNDERGROUND UTILITIES IN THE AREA CONTRACTOR IS RESPONSIBLE FOR DETERMINING THE HORIZONTAL AND VERTICAL LOCATION OF ALL UTILITIES PRIOR TO CONSTRUCTION. CONTRACTOR SHALL BE RESPONSIBLE FOR ANY REPAIRS TO EXISTING UTILITIES DUE TO DAMAGE INCURRED DURING CONSTRUCTION. CONTRACTOR SHALL NOTIFY THE ENGINEER OF ANY DISCREPANCIES ON THE PLANS.



1

2

3

4

5

D

C

B

A

NO.	REVISIONS	DATE	BY

Kimley-Horn

© 2024 KIMLEY-HORN AND ASSOCIATES, INC.
10101 REIMON PLACE, SUITE 400, SAN ANTONIO, TX 78216
WWW.KIMLEY-HORN.COM | TBE FIRM NO. 928

STATE OF TEXAS

MATTHEW G. MATNEY
196733

03/29/2024

KHA PROJECT 069401104
DATE 3/29/2024
SCALE AS SHOWN
DESIGNED BY ARC
DRAWN BY ARC
CHECKED BY MGV

DETENTION AND WATER QUALITY POND A

BANDERA RANCH PREPARED FOR PARAVEL CAPITAL

TX

HELOTES

SHEET NUMBER **C9.0**

Project: B:\CADD\11-29-24\11-29-24 - Benders Beach - 8751-01-01\Drawings\Sheet\11-29-24\11-29-24.dwg
 This document, together with the concepts and designs presented herein, is intended only for the specific purpose and client for which it was prepared. Reuse of and improper reliance on this document without written authorization and adaptation by Kimley-Horn and Associates, Inc. shall be without liability to Kimley-Horn and Associates, Inc.

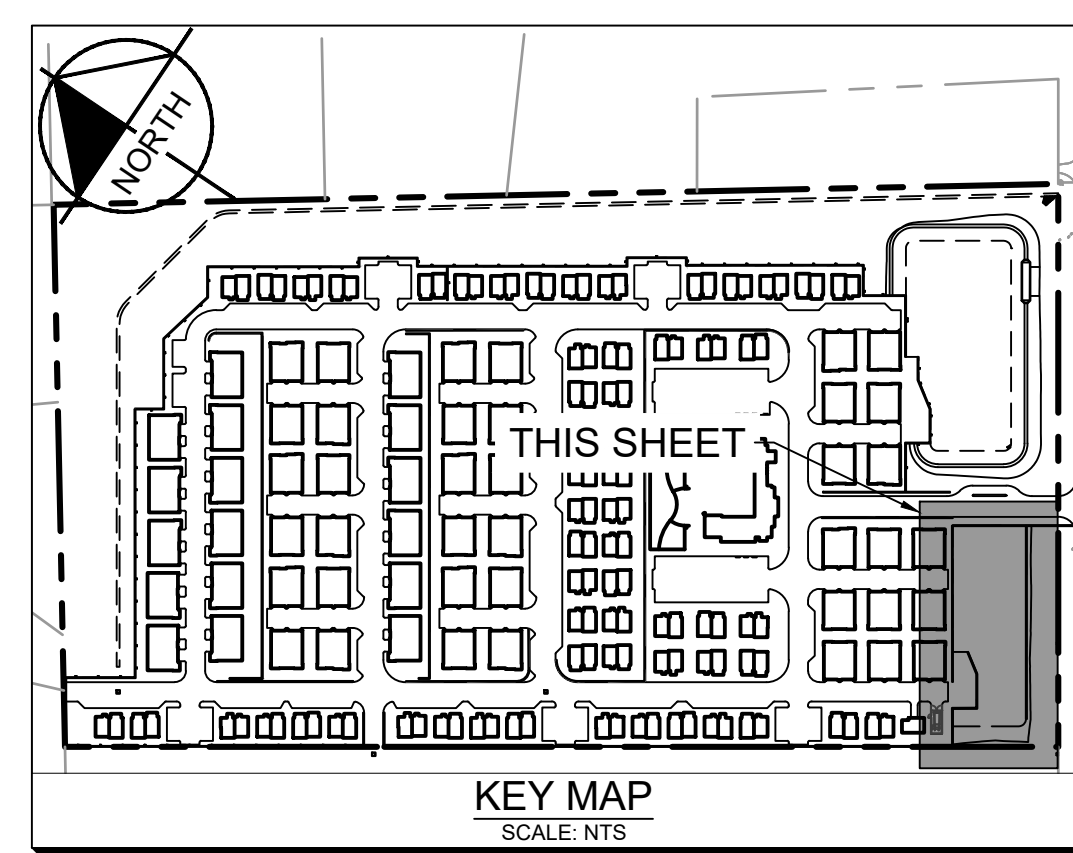
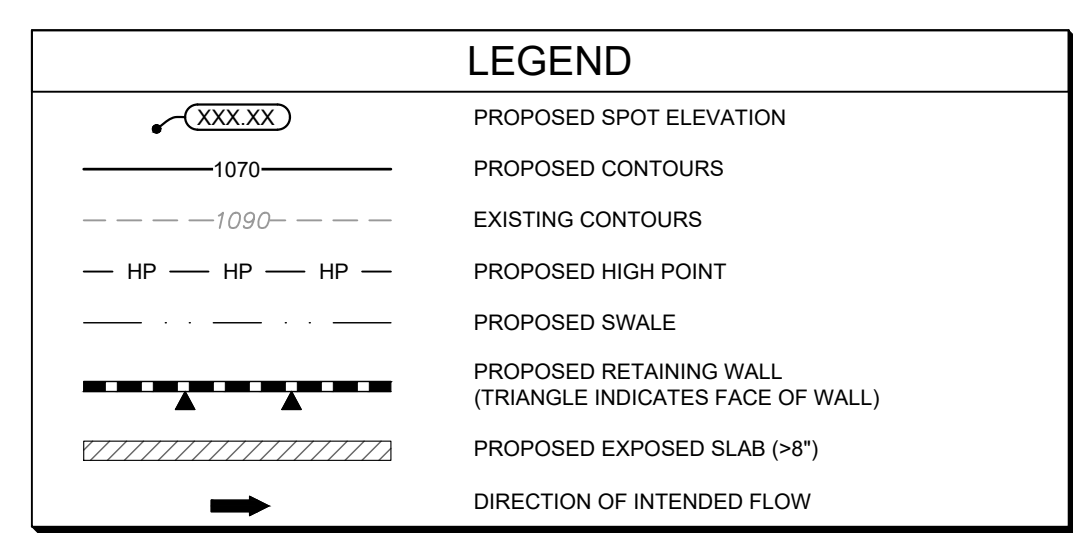
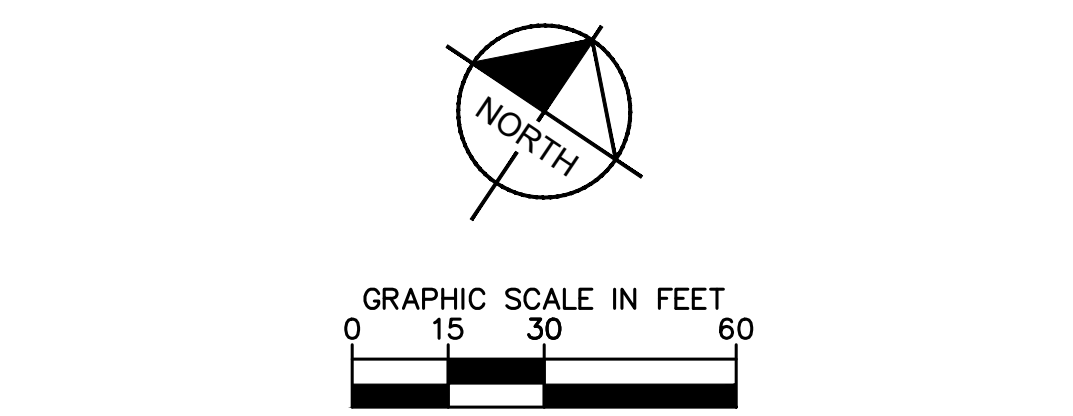
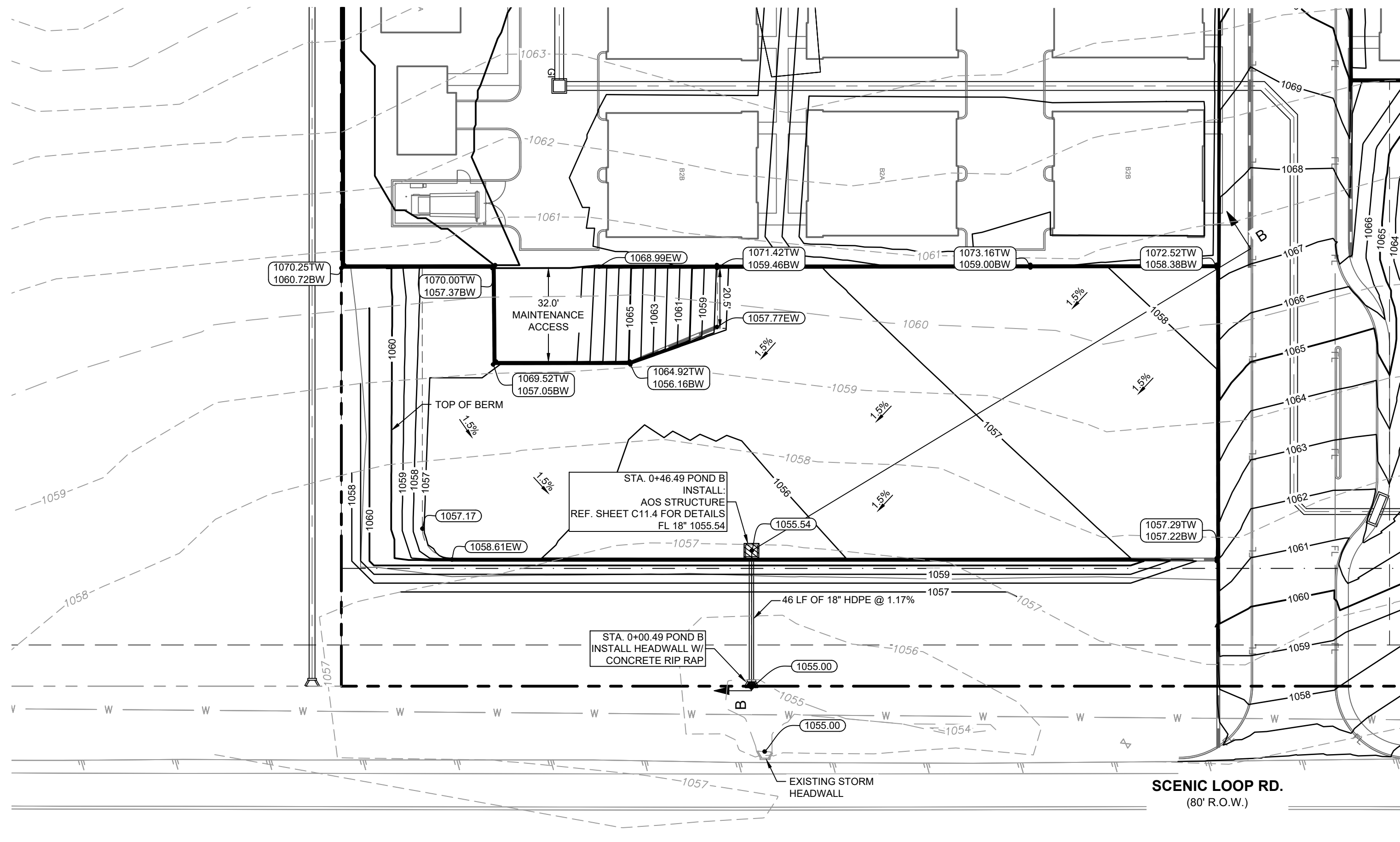

- ### STORM NOTES
1. ALL DIMENSIONS ARE TO CENTERLINE OF PIPE UNLESS NOTED OTHERWISE.
 2. REFERENCE SAWS CONSTRUCTION STANDARDS FOR PIPE MATERIAL REQUIREMENTS.
 3. REFERENCE SHEET C12.3 FOR STORM SEWER DETAILS.
 4. CONTRACTOR TO FIELD VERIFY LOCATION OF ALL UTILITIES PRIOR TO CONSTRUCTION. CONTACT ENGINEER IF FIELD CONDITIONS VARY.

STAGE ELEVATION (FT.)	AREA (SQ. FT.)	INC. VOL (CU. FT.)	CUM. VOL (CU. FT.)
1055.50	0		
1056.00	2,812	703	703
1057.00	15,704	9,258	9,961
1057.30	18,492	5,129	15,090
1058.00	24,999	20,352	30,313
1059.00	25,836	25,418	55,730
1060.00	26,044	25,940	81,670

ITEM	QUANTITY
WQ VOLUME REQUIRED	14,628 CF
WQ VOLUME PROVIDED	15,090 CF
WQ STORAGE DEPTH	1.76 FT

BENCHMARK LIST

BW# 1
 3\"/>

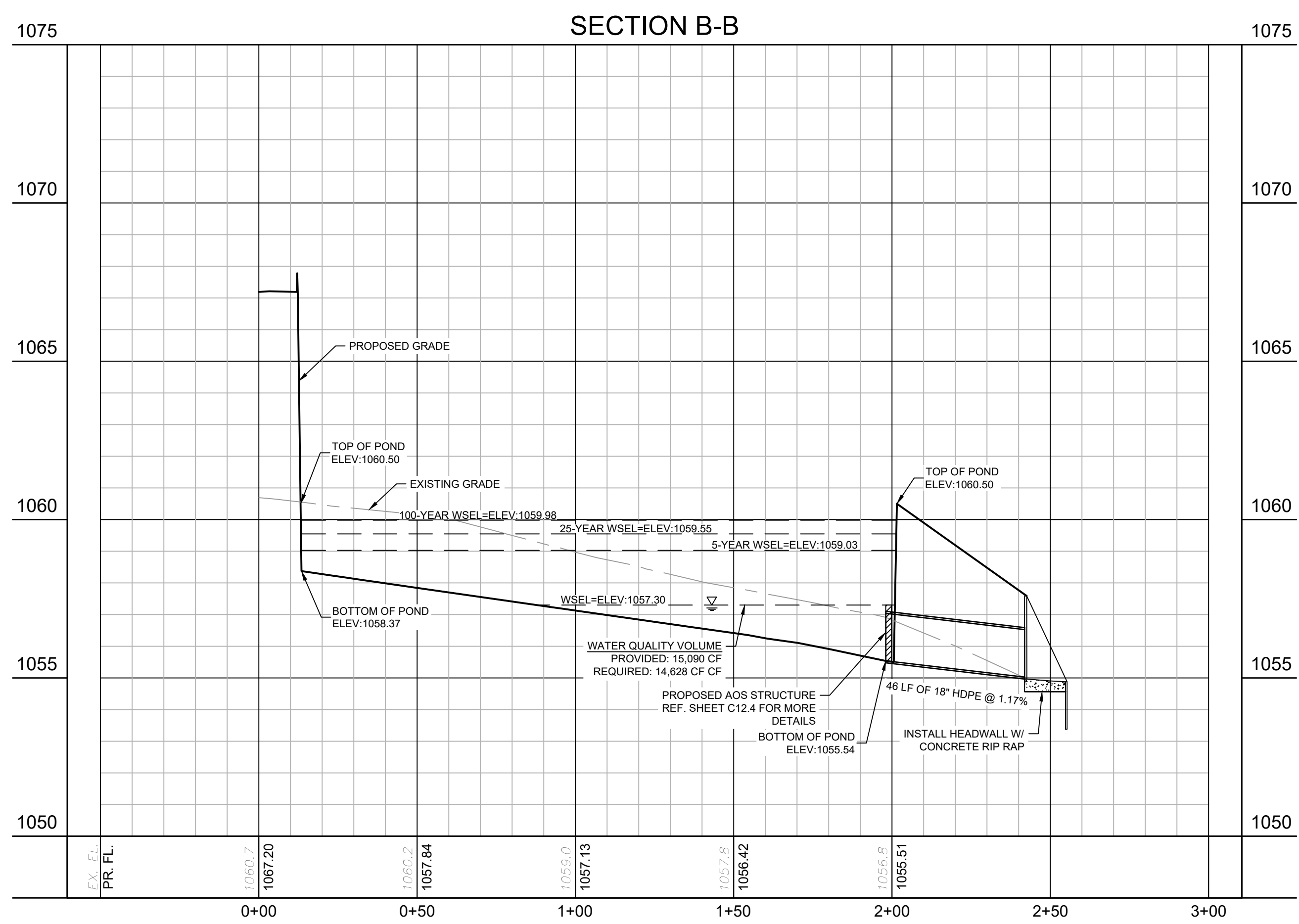

CAUTION!
 EXISTING UNDERGROUND UTILITIES IN THE AREA CONTRACTOR IS RESPONSIBLE FOR DETERMINING THE HORIZONTAL AND VERTICAL LOCATION OF ALL UTILITIES PRIOR TO CONSTRUCTION. CONTRACTOR SHALL BE RESPONSIBLE FOR ANY REPAIRS TO EXISTING UTILITIES DUE TO DAMAGE INCURRED DURING CONSTRUCTION. CONTRACTOR SHALL NOTIFY THE ENGINEER OF ANY DISCREPANCIES ON THE PLANS.

 <small>© 2024 KIMLEY-HORN AND ASSOCIATES, INC. 10101 REBORN PLACE, SUITE 400, SAN ANTONIO, TX 78216 WWW.KIMLEY-HORN.COM TBE FIRM NO. 928</small>	 <small>MATTHEW G. MATNEY 196733</small>
KHA PROJECT: 069401104 DATE: 3/29/2024 SCALE: AS SHOWN DESIGNED BY: ARC DRAWN BY: ARC CHECKED BY: MGM	REVISIONS No. _____ BY _____ DATE _____
BANDERA RANCH PREPARED FOR PARAVEL CAPITAL	DETENTION AND WATER QUALITY POND B
SHEET NUMBER C9.1	HELOTES TX

*Bandera Ranch Development
Contributing Zone Plan
Attachment N*

Inspection, Maintenance, Repair and Retrofit Plan

The inspection and maintenance plan outlines the procedures necessary to maintain the performance of the Permanent Best Management Practices for this project. It should be noted that the plan provides guidelines that may have to be adjusted dependent on site-specific and weather-related conditions.

It is the responsibility of the owner of the property to provide the inspections and maintenance as outlined in the plan for the duration of the project. The owner will maintain this responsibility until it is assumed or transferred to another entity in writing. If the property is leased or sold, the responsibility for the maintenance will be required to be transferred through the lease agreement, binding covenants, closing documents, or other binding legal instrument.

Disposal of accumulated silt shall be accomplished following Texas Commission on Environmental Quality guidelines and specifications.

Maintenance records shall be kept on the installation, maintenance, or removal of items necessary for the proper operation of the facilities. All inspections shall be documented.

An amended copy of this document will be provided to the Texas Commission on Environmental Quality within thirty (30) days of any changes in the following information:

Responsible Party: Helotes Bandera Ranch, LP
Mailing Address: 1509 Old West 8th St., Suite 3
City, State: Austin, Texas 78731
Telephone: 512-934-8923

I, the owner, have read and understand the requirements of the attached Inspection and Maintenance Plan for the proposed Permanent Best Management Practices for my project. I acknowledge that I will maintain responsibility for the implementation and execution of the plan until the responsibility is transferred to or assumed by another party in writing through a binding legal instrument.

Name of Responsible Party (Print): Curtis Thigpen

Signature of Responsible Party:  Date: 3-29-24

Maintenance on Batch Detention Basins

Regular, routine maintenance is essential to effective, long-lasting performance of batch detention basins. Neglect or failure to service the filters regularly will lead to poor performance and eventual costly repairs. It is recommended that batch detention basins be inspected at a minimum of twice a year. The first inspection should occur after the first indications of wet weather to ensure the requirements are being met. The remaining inspections shall occur in between storm events. Debris and sediment shall be removed if found in the level sensor, orifice, and outlet(s).

Indications of the need for maintenance:

- Clogging in the outlet or trash screen
- Damage to the structural elements of the system

Other recommended maintenance guidelines include:

- *Sediment Removal.* Remove sediment from the basin at least every 5 years or when the sediment depth is greater than 6 inches. Sediment should be cleared when the sediment intervenes with the level sensor or if the basin has not drained within 48 hours.
- *Debris and Litter Removal.* Debris and litter will accumulate near the sedimentation basin outlet device and should be removed during regular mowing operations and inspections at least twice a year. Particular attention should be paid to floating debris that can eventually clog the control device or riser and be removed at once.
- *Structural Repairs and Replacement.* Damage to the structural elements of the basin shall be inspected, identified, and repaired immediately if needed.
- *Mowing.* Grass areas in and around the batch detention basin must be mowed to limit vegetation height to 18 inches. More frequent mowing to maintain aesthetic appeal may be necessary in landscaped areas.

ATTACHMENT O-PILOT -SCALE FIELD TESTING PLAN

The TCEQ Technical Guidance Manual (TGM) was used to design permanent detention/water quality ponds and sand filter measures for this site; therefore pilot-scale field testing is not required.

**ATTACHMENT P – Measures for Minimizing Surface
Stream Contamination**

Any points where discharge from the site is concentrated and excessive velocities exist will include appropriately sized energy dissipaters to reduce velocities to non-erosive levels.

Temporary Stormwater Section

Texas Commission on Environmental Quality

for Regulated Activities on the Edwards Aquifer Recharge Zone and Relating to 30 TAC §213.5(b)(4)(A), (B), (D)(I) and (G); Effective June 1, 1999

To ensure that the application is administratively complete, confirm that all fields in the form are complete, verify that all requested information is provided, consistently reference the same site and contact person in all forms in the application, and ensure forms are signed by the appropriate party.

Note: Including all the information requested in the form and attachments contributes to more streamlined technical reviews.

Signature

To the best of my knowledge, the responses to this form accurately reflect all information requested concerning the proposed regulated activities and methods to protect the Edwards Aquifer. This Temporary Stormwater Section is hereby submitted for TCEQ review and executive director approval. The application was prepared by:

Print Name of Customer/Agent: Matthew G. Matney, P.E.

Date: 03/29/2024

Signature of Customer/Agent:



Regulated Entity Name: Bandera Ranch

Project Information

Potential Sources of Contamination

Examples: Fuel storage and use, chemical storage and use, use of asphaltic products, construction vehicles tracking onto public roads, and existing solid waste.

1. Fuels for construction equipment and hazardous substances which will be used during construction:

The following fuels and/or hazardous substances will be stored on the site: _____

These fuels and/or hazardous substances will be stored in:

Aboveground storage tanks with a cumulative storage capacity of less than 250 gallons will be stored on the site for less than one (1) year.

- Aboveground storage tanks with a cumulative storage capacity between 250 gallons and 499 gallons will be stored on the site for less than one (1) year.
- Aboveground storage tanks with a cumulative storage capacity of 500 gallons or more will be stored on the site. An Aboveground Storage Tank Facility Plan application must be submitted to the appropriate regional office of the TCEQ prior to moving the tanks onto the project.
- Fuels and hazardous substances will not be stored on the site.
- 2. Attachment A - Spill Response Actions. A site specific description of the measures to be taken to contain any spill of hydrocarbons or hazardous substances is attached.
- 3. Temporary aboveground storage tank systems of 250 gallons or more cumulative storage capacity must be located a minimum horizontal distance of 150 feet from any domestic, industrial, irrigation, or public water supply well, or other sensitive feature.
- 4. Attachment B - Potential Sources of Contamination. A description of any activities or processes which may be a potential source of contamination affecting surface water quality is attached.

Sequence of Construction

- 5. Attachment C - Sequence of Major Activities. A description of the sequence of major activities which will disturb soils for major portions of the site (grubbing, excavation, grading, utilities, and infrastructure installation) is attached.
 - For each activity described, an estimate (in acres) of the total area of the site to be disturbed by each activity is given.
 - For each activity described, include a description of appropriate temporary control measures and the general timing (or sequence) during the construction process that the measures will be implemented.
- 6. Name the receiving water(s) at or near the site which will be disturbed or which will receive discharges from disturbed areas of the project: Helotes Creek

Temporary Best Management Practices (TBMPs)

Erosion control examples: tree protection, interceptor swales, level spreaders, outlet stabilization, blankets or matting, mulch, and sod. Sediment control examples: stabilized construction exit, silt fence, filter dikes, rock berms, buffer strips, sediment traps, and sediment basins. Please refer to the Technical Guidance Manual for guidelines and specifications. All structural BMPs must be shown on the site plan.

- 7. Attachment D – Temporary Best Management Practices and Measures. TBMPs and measures will prevent pollution of surface water, groundwater, and stormwater. The construction-phase BMPs for erosion and sediment controls have been designed to retain sediment on site to the extent practicable. The following information is attached:

- A description of how BMPs and measures will prevent pollution of surface water, groundwater or stormwater that originates upgradient from the site and flows across the site.
 - A description of how BMPs and measures will prevent pollution of surface water or groundwater that originates on-site or flows off site, including pollution caused by contaminated stormwater runoff from the site.
 - A description of how BMPs and measures will prevent pollutants from entering surface streams, sensitive features, or the aquifer.
 - A description of how, to the maximum extent practicable, BMPs and measures will maintain flow to naturally-occurring sensitive features identified in either the geologic assessment, TCEQ inspections, or during excavation, blasting, or construction.
8. The temporary sealing of a naturally-occurring sensitive feature which accepts recharge to the Edwards Aquifer as a temporary pollution abatement measure during active construction should be avoided.
- Attachment E - Request to Temporarily Seal a Feature. A request to temporarily seal a feature is attached. The request includes justification as to why no reasonable and practicable alternative exists for each feature.
 - There will be no temporary sealing of naturally-occurring sensitive features on the site.
9. Attachment F - Structural Practices. A description of the structural practices that will be used to divert flows away from exposed soils, to store flows, or to otherwise limit runoff discharge of pollutants from exposed areas of the site is attached. Placement of structural practices in floodplains has been avoided.
10. Attachment G - Drainage Area Map. A drainage area map supporting the following requirements is attached:
- For areas that will have more than 10 acres within a common drainage area disturbed at one time, a sediment basin will be provided.
 - For areas that will have more than 10 acres within a common drainage area disturbed at one time, a smaller sediment basin and/or sediment trap(s) will be used.
 - For areas that will have more than 10 acres within a common drainage area disturbed at one time, a sediment basin or other equivalent controls are not attainable, but other TBMPs and measures will be used in combination to protect down slope and side slope boundaries of the construction area.
 - There are no areas greater than 10 acres within a common drainage area that will be disturbed at one time. A smaller sediment basin and/or sediment trap(s) will be used in combination with other erosion and sediment controls within each disturbed drainage area.

- There are no areas greater than 10 acres within a common drainage area that will be disturbed at one time. Erosion and sediment controls other than sediment basins or sediment traps within each disturbed drainage area will be used.
11. Attachment H - Temporary Sediment Pond(s) Plans and Calculations. Temporary sediment pond or basin construction plans and design calculations for a proposed temporary BMP or measure have been prepared by or under the direct supervision of a Texas Licensed Professional Engineer. All construction plans and design information must be signed, sealed, and dated by the Texas Licensed Professional Engineer. Construction plans for the proposed temporary BMPs and measures are attached.
- N/A
12. Attachment I - Inspection and Maintenance for BMPs. A plan for the inspection of each temporary BMP(s) and measure(s) and for their timely maintenance, repairs, and, if necessary, retrofit is attached. A description of the documentation procedures, recordkeeping practices, and inspection frequency are included in the plan and are specific to the site and/or BMP.
13. All control measures must be properly selected, installed, and maintained in accordance with the manufacturer's specifications and good engineering practices. If periodic inspections by the applicant or the executive director, or other information indicate a control has been used inappropriately, or incorrectly, the applicant must replace or modify the control for site situations.
14. If sediment escapes the construction site, off-site accumulations of sediment must be removed at a frequency sufficient to minimize offsite impacts to water quality (e.g., fugitive sediment in street being washed into surface streams or sensitive features by the next rain).
15. Sediment must be removed from sediment traps or sedimentation ponds not later than when design capacity has been reduced by 50%. A permanent stake will be provided that can indicate when the sediment occupies 50% of the basin volume.
16. Litter, construction debris, and construction chemicals exposed to stormwater shall be prevented from becoming a pollutant source for stormwater discharges (e.g., screening outfalls, picked up daily).

Soil Stabilization Practices

Examples: establishment of temporary vegetation, establishment of permanent vegetation, mulching, geotextiles, sod stabilization, vegetative buffer strips, protection of trees, or preservation of mature vegetation.

17. Attachment J - Schedule of Interim and Permanent Soil Stabilization Practices. A schedule of the interim and permanent soil stabilization practices for the site is attached.

18. Records must be kept at the site of the dates when major grading activities occur, the dates when construction activities temporarily or permanently cease on a portion of the site, and the dates when stabilization measures are initiated.
19. Stabilization practices must be initiated as soon as practicable where construction activities have temporarily or permanently ceased.

Administrative Information

20. All structural controls will be inspected and maintained according to the submitted and approved operation and maintenance plan for the project.
21. If any geologic or manmade features, such as caves, faults, sinkholes, etc., are discovered, all regulated activities near the feature will be immediately suspended. The appropriate TCEQ Regional Office shall be immediately notified. Regulated activities must cease and not continue until the TCEQ has reviewed and approved the methods proposed to protect the aquifer from any adverse impacts.
22. Silt fences, diversion berms, and other temporary erosion and sediment controls will be constructed and maintained as appropriate to prevent pollutants from entering sensitive features discovered during construction.

ATTACHMENT A – SPILL RESPONSE ACTIONS

The following are measures to be taken for any spills of hydrocarbons or hazardous substances:

Education

- (1) Be aware that different materials pollute in different amounts. Make sure that each employee knows what a “significant spill” is for each material they use, and what is the appropriate response for “significant” and “insignificant” spills. Employees should also be aware of when spill must be reported to the TCEQ. Information available in 30 TAC 327.4 and 40 CFR 302.4.
- (2) Educate employees and subcontractors on potential danger to humans and the environment from spills and leaks.
- (3) Hold regular meetings to discuss and reinforce appropriate disposal procedures (incorporate into regular safety meetings).
- (4) Establish a continuing education program to indoctrinate new employees.
- (5) Have contractor’s superintendent or representative oversee and enforce proper spill prevention and control measures.

General Measures

- (1) To the extent that the work can be accomplished safely, spills of oil, petroleum products, substances listed under 40 CFR parts 110, 117, and 302, and sanitary and septic wastes should be contained and cleaned up immediately.
- (2) Store hazardous materials and wastes in covered containers and protect from vandalism.
- (3) Place a stockpile of spill cleanup materials where it will be readily accessible.
- (4) Train employees in spill prevention and cleanup.
- (5) Designate responsible individuals to oversee and enforce control measures.
- (6) Spills should be covered and protected from stormwater run-on during rainfall to the extent that it doesn’t compromise cleanup activities.
- (7) Do not bury or wash spills with water.
- (8) Store and dispose of used clean up materials, contaminated materials, and

Bandera Ranch Development Contributing Zone Plan

recovered spill material that is no longer suitable for the intended purpose in conformance with the provisions in applicable BMPs.

(9) Do not allow water used for cleaning and decontamination to enter storm drains or watercourses. Collect and dispose of contaminated water in accordance with applicable regulations.

(10) Contain water overflow or minor water spillage and do not allow it to discharge into drainage facilities or watercourses.

(11) Place Material Safety Data Sheets (MSDS), as well as proper storage, cleanup, and spill reporting instructions for hazardous materials stored or used on the project site in an open, conspicuous, and accessible location.

(12) Keep waste storage areas clean, well-organized, and equipped with ample cleanup supplies as appropriate for the materials being stored. Perimeter controls, containment structures, cover, and liners should be repaired or replaced as needed to maintain proper function.

Cleanup

(1) Clean up leaks and spills immediately.

(2) Use a rag for small spills on paved surfaces, a damp mop for general cleanup, and absorbent material for larger spills. If the spilled material is hazardous, then the used cleanup materials are also hazardous and must be disposed of as hazardous waste.

(3) Never hose down or bury dry material spills. Clean up as much of the material as possible and dispose of properly. See the waste management BMPs in this section for specific information.

Minor Spills

(1) Minor spills typically involve small quantities of oil, gasoline, paint, etc. which can be controlled by the first responder at the discovery of the spill.

(2) Use absorbent materials on small spills rather than hosing down or burying the spill.

(3) Absorbent materials should be promptly removed and disposed of properly.

(4) Follow the practice below for a minor spill:

(5) Contain the spread of the spill.

**Bandera Ranch Development
Contributing Zone Plan**

- (6) Recover spilled materials.
- (7) Clean the contaminated area and properly dispose of contaminated materials.

Semi-Significant Spills – can be controlled by the first responder along with the aid of other personnel such as laborers and the foreman, etc. This response may require the cessation of all other activities. Spills should be cleaned up immediately:

- (1) Contain spread of the spill.
- (2) Notify the project foreman immediately.
- (3) If the spill occurs on paved or impermeable surfaces, clean up using “dry” methods (absorbent materials, cat litter and/or rags). Contain the spill by encircling with absorbent materials and do not let the spill spread widely.
- (4) If the spill occurs in dirt areas, immediately contain the spill by constructing an earthen dike. Dig up and properly dispose of contaminated soil.
- (5) If the spill occurs during rain, cover spill with tarps or other material to prevent contaminating runoff.

Significant/Hazardous Spills

For significant or hazardous spills that are in reportable quantities:

- (1) Notify the TCEQ by telephone as soon as possible and within 24 hours at 512- 339-2929 (Austin) or 210-490-3096 (San Antonio) between 8 AM and 5 PM. After hours, contact the Environmental Release Hotline at 1-800-832-8224. It is the contractor’s responsibility to have all emergency phone numbers at the construction site.
- (2) For spills of federal reportable quantities, in conformance with the requirements on 40 CFR parts 110, 119, and 302, the contractor should notify the National Response Center at (800) 424-8802.
- (3) Notification should first be made by telephone and followed up with a written report.
- (4) The services of a spills contractor or a Haz-Mat team should be obtained immediately. Construction personnel should not attempt to clean up until the appropriate and qualified staffs have arrived at the job site.
- (5) Other agencies which may need to be consulted include, but are not limited to, the City Police Department, County Sheriff Office, Fire Departments, etc.

ATTACHMENT B – POTENTIAL SOURCES OF CONTAMINATION

The following are sources of contamination that can occur during construction and the preventative measure than can be taken:

Potential Source	Preventative Measure
Asphalt Products Used on this Project	After placement of Asphalt, emulsion or coatings, the contractor will be responsible for immediate cleanup should an unexpected rain occur. For the duration of the asphalt product curing time, the contractor will maintain standby personnel and equipment to contain any asphalt wash-off should an unexpected rain occur. The Contractor will be instructed not to place asphalt products on the ground within 48 hours of a forecasted rain event.
Oil, Grease, Fuel, and Hydraulic Fluid Drippings	Vehicle maintenance when possible will be performed within the construction staging area.
Miscellaneous Trash and Litter	Trash containers will be placed throughout the site to encourage proper trash disposal.
Construction Debris	Construction debris will be monitored daily by the contractor. Debris will be collected weekly and placed in disposal bins. Situations requiring immediate attention will be addressed on a case-by-case basis.

ATTACHMENT C – SEQUENCE OF MAJOR ACTIVITIES

The installation of erosion and sedimentation controls shall occur before any excavation of materials or major disturbances of the site.

The sequence of major construction activities will be as follows. Approximate acreage to be disturbed is listed in parenthesis next to each activity.

Lot 1 – Proposed Multi-family Development

1. Install all temporary erosion controls. (27.69 Acres)
2. Clear and grub strip topsoil. (18.42 Acres)
3. Grading. (18.42 Acres)
4. Rough Cut Drive Aisles and Building Pads. (3.56 Acres)
5. Install Wet/Dry Utilities. (2.66 Acres)
6. Install paving improvements. (5.25 Acres)
7. Complete restoration of site vegetation. (11.49 Acres)
8. Remove and dispose of temporary erosion controls when restoration has been accepted.

Lot 2 – Future Commercial Development

1. Install all temporary erosion controls. (8.43 Acres)
2. Clear and grub strip topsoil. (8.43 Acres)
3. Grading. (8.43 Acres)
4. Rough Cut Drive Aisles and Building Pads. (3.82 Acres)
5. Install Wet/Dry Utilities. (2.50 Acres)
6. Install paving improvements. (5.25 Acres)
7. Complete restoration of site vegetation. (3.18 Acres)
8. Remove and dispose of temporary erosion controls when restoration has been accepted.

ATTACHMENT D – TEMPORARY BEST MANAGEMENT PRACTICES AND MEASURES

Also refer to the TCEQ Site Plan for details of TBMP's.

Silt fencing will be installed prior to the commencement of construction to prohibit runoff of sediment. The silt fence shall be placed perpendicular to direction of flow, where feasible, to maximize efficiency. If there are any, potentially sensitive features, a silt fence will surround the site as specified by TCEQ Guidance Manual Chapter 5.

Bagged gravel inlet filters will be used and maintained in a condition to prevent runoff of sediment from flowing into drains during construction.

Stabilized construction entrance will be installed prior to the commencement of construction and will be used and maintained in a condition that will prevent tracking or flowing of sediment onto public roadway.

a.) Silt fence will not be placed on the upstream side of the site because there will be no stormwater that originates upgradient of the site. All upgradient stormwater is captured in onsite storm water system that discharges to an existing batch detention pond.

b.) Silt fencing and bagged gravel inlet filters will be used on-site to filter out pollutants and restrict sediment from leaving the site. Silt fencing will be placed in existing and proposed channels and downstream of flow on site. Bagged gravel inlet filters will be placed around proposed inlets to capture any suspended solids.

c.) Temporary measures are intended to provide a method of slowing the flow of runoff from the construction site in order to allow sediment and suspended solids to settle out of the runoff. Silt Fencing, bagged gravel inlet filters and construction entrance measures prevent sediment and pollution by filtering and routing water. These filtered pollutants are then removed and prevented from entering surface streams, sensitive features, or the aquifer.

d.) BMP measures utilized in this plan are intended to allow stormwater to continue downstream after passing through the BMP's. Silt fencing and bagged gravel inlet filters will be placed to intercept and detain water with sediment or pollution from entering or leaving the site to any unprotected areas. The BMP's will filter out sediment and pollution while allowing filtered water to flow to naturally-occurring sensitive features identified in either the geologic assessment, TCEQ inspections, or during excavation, blasting, or construction.

e.) Sediment must be removed from sediment traps and sedimentation ponds no later than the time that design capacity has been reduced by 50%. For perimeter controls such as silt fences, berms, etc., the trapped sediment must be removed before it reaches 50% of the above-ground height.

ATTACHMENT E – Request to Temporarily Seal a Feature

(Not applicable)

ATTACHMENT F – Structural Practices

The structural practices that will be used to divert and store flows and limit runoff discharge or pollutants will be the use of silt fences, inlet protection, and construction entrance stabilization.

ATTACHMENT G- Drainage Area Map

The existing and proposed drainage maps are provided with this submittal.
A smaller sediment basin will be provided for areas with more than 10 acres within a common drainage area disturbed at one time.

EROSION CONTROL SCHEDULE AND SEQUENCING

I. ROUGH GRADING/ DEMOLITION	CONSTRUCTION ENTRANCE/EXIT, TREE PROTECTION, FILTER DAMS AND SILT FENCE PROTECTION SHALL BE INSTALLED PRIOR TO THE INITIATION OF ROUGH GRADING, AS NEEDED.
II. UTILITY INSTALLATION	ALL PRIOR EROSION CONTROL MEASURES INSTALLED ABOVE TO BE MAINTAINED AS NECESSARY DURING UTILITY INSTALLATION.
III. PAVING	ALL PRIOR EROSION CONTROL MEASURES INSTALLED ABOVE TO BE MAINTAINED AS NECESSARY DURING PAVING AND THROUGHOUT THE REMAINDER OF THE PROJECT.
IV. FINAL GRADING/ SOIL STABILIZATION/ LANDSCAPING	ALL TEMPORARY EROSION CONTROL MEASURES TO BE REMOVED AT THE CONCLUSION OF THE PROJECT AS DIRECTED BY THE CITY OR COUNTY.

* THE SEQUENCE OF CONSTRUCTION SHOWN ABOVE IS A GENERAL OVERVIEW AND IS INTENDED TO CONVEY THE GENERAL CONCEPTS OF THE EROSION CONTROL DESIGN AND SHOULD NOT BE RELIED UPON FOR CONSTRUCTION PURPOSES. THE CONTRACTOR IS SOLELY RESPONSIBLE FOR DETAILED PHASING AND CONSTRUCTION SEQUENCING NECESSARY TO CONSTRUCT THE PROPOSED IMPROVEMENTS INCLUDED IN THESE PLANS. THE CONTRACTOR SHALL NOTIFY ENGINEER IN WRITING IMMEDIATELY PRIOR TO AND/OR DURING CONSTRUCTION IF ANY ADDITIONAL INFORMATION ON THE CONSTRUCTION SEQUENCE IS NECESSARY. CONTRACTOR IS SOLELY RESPONSIBLE FOR COMPLYING WITH THE REQUIREMENTS OF THE AUTHORITY HAVING JURISDICTION AND ALL OTHER APPLICABLE LAWS.

NOTES

- AREAS CONTAINED WITHIN THE PROPERTY BOUNDARIES WILL BE AREAS OF DISTURBANCE AND SOIL STABILIZATION. ALL SOILS WITHIN THESE LIMITS SHALL BE STABILIZED BY VEGETATION OR STRUCTURE.
- REFERENCE LANDSCAPE PLANS, BY OTHERS, FOR THE TREE PRESERVATION AND MITIGATION PLAN.

SITE DATA

TOTAL LOT AREA	31.463 AC	1,370,528 SF
TOTAL AREA DISTURBED *	18.67 AC	813,265 SF

* DOES NOT INCLUDE ANY OFF-SITE DISPOSAL OR BORROW AREAS - CONTRACTOR TO UPDATE AS NECESSARY DURING CONSTRUCTION.

SEDIMENT BASIN DATA TABLE #1

DISTURBED AREA (AC.)	13.82
DRAINAGE AREA (AC.)	19.99
Q ₁₀ TREATMENT FLOW (CFS)	12.8
Q ₁₀ SPILLWAY FLOW (CFS)	12.8
STORAGE VOLUME REQUIRED (CU. FT.)	156,949
STORAGE VOLUME PROVIDED (CU. FT.)	82,804
BASIN BOTTOM ELEVATION (FT)	1054.00
OVERFLOW WEIR ELEVATION (FT)	1059.80
TOP OF BERM ELEVATION (FT)	1058.80
TEMP. BARREL INVERT ELEVATION (FT)	1053.98
SKIMMER SIZE (IN)	4"
SKIMMER ORIFICE RADIUS (IN)	4.00
TIME TO DEWATER BASIN (SKIMMER DRAINDOWN TIME IN DAYS)	2
ANTI-FLOATATION BLOCK DEPTH (FT)	1.5

SEDIMENT BASIN DATA TABLE #2

DISTURBED AREA (AC.)	4.85
DRAINAGE AREA (AC.)	7.50
Q ₁₀ TREATMENT FLOW (CFS)	17.5
Q ₁₀ SPILLWAY FLOW (CFS)	17.5
STORAGE VOLUME REQUIRED (CU. FT.)	50,217
STORAGE VOLUME PROVIDED (CU. FT.)	39,203
BASIN BOTTOM ELEVATION (FT)	1055.50
OVERFLOW WEIR ELEVATION (FT)	1060.50
TOP OF BERM ELEVATION (FT)	1059.50
TEMP. BARREL INVERT ELEVATION (FT)	1055.50
SKIMMER SIZE (IN)	6"
SKIMMER ORIFICE RADIUS (IN)	2.30
TIME TO DEWATER BASIN (SKIMMER DRAINDOWN TIME IN DAYS)	2
ANTI-FLOATATION BLOCK DEPTH (FT)	1.5

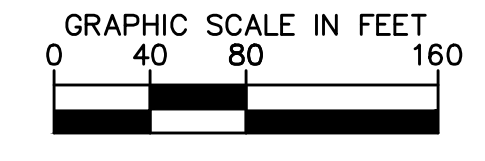
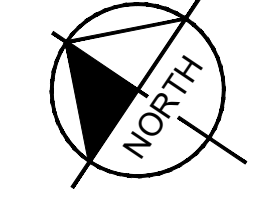

LEGEND

	PROPERTY BOUNDARY
	EXISTING CONTOUR
	PROPOSED CONTOUR
	DRAINAGE BOUNDARY
	SILT FENCE (SEE DETAIL SHEET C3.1)
	TREE PROTECTION (SEE DETAIL SHEET C3.1)
	CONSTRUCTION EXIT (SEE DETAIL SHEET C3.1)
	PERMANENT STABILIZATION
	STONE OVERFLOW (SEE DETAIL SHEET C3.1)
	TREE TO REMAIN
	CHECK DAM (SEE DETAIL SHEET C2.1)
	RIPRAP (SEE DETAIL SHEET C2.1)
	INTERCEPTOR SWALE (SEE DETAIL SHEET C2.1)
	FAIRCLOTH SKIMMER (SEE DETAIL SHEET C2.1)

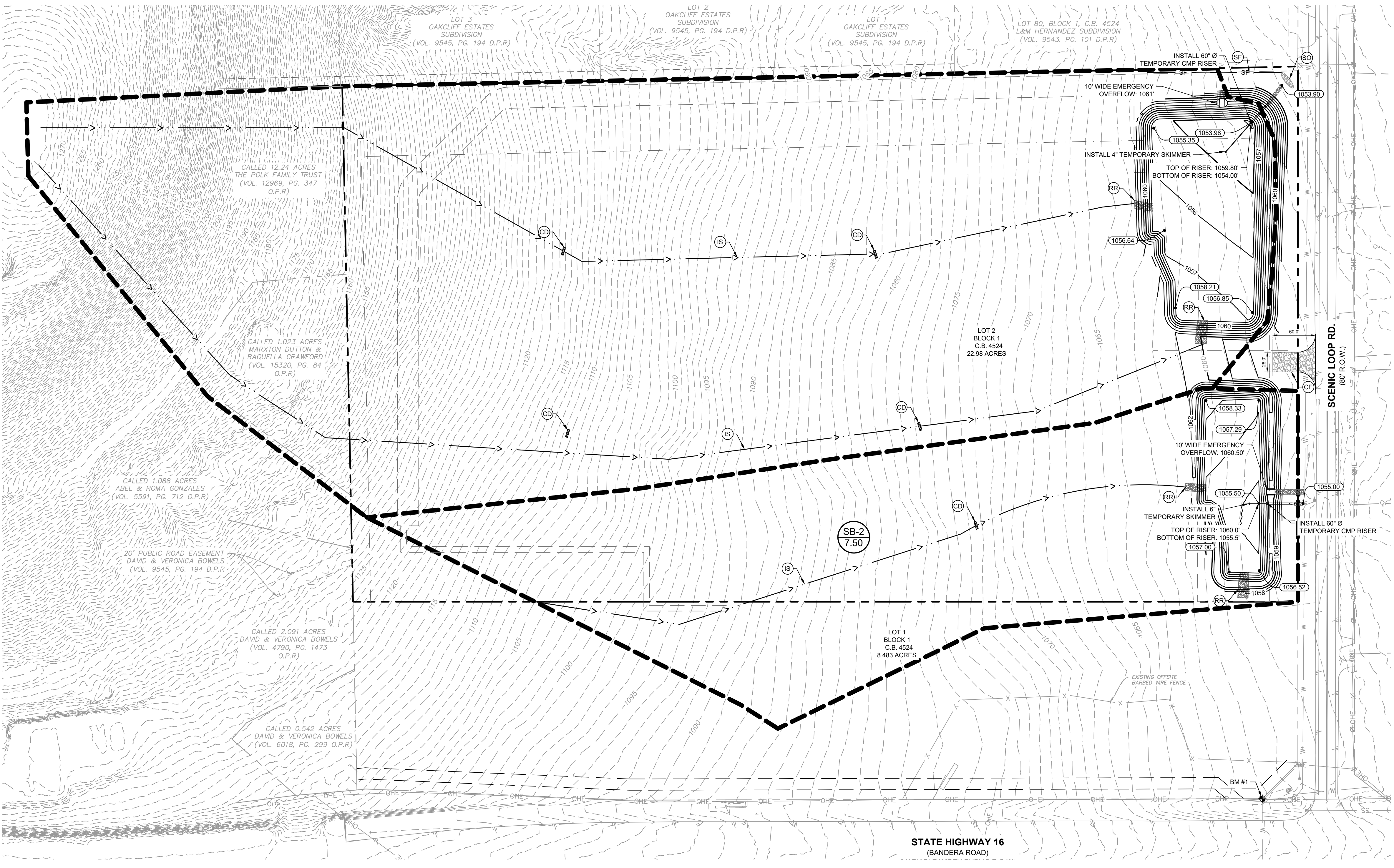

STATE HIGHWAY 16
(BANDERA ROAD)



BENCHMARK LIST

BM# 1	1" IRON ROD FOUND WITH YELLOW CAP MARKED "PAPE-DAWSON" AT A SOUTHWEST CORNER OF SAID 31.460 ACRE TRACT ELEVATION: 1050.67
-------	---

CAUTION!
EXISTING UNDERGROUND UTILITIES IN THE AREA CONTRACTOR IS RESPONSIBLE FOR DETERMINING THE HORIZONTAL AND VERTICAL LOCATION OF ALL UTILITIES PRIOR TO CONSTRUCTION. CONTRACTOR SHALL BE RESPONSIBLE FOR ANY REPAIRS TO EXISTING UTILITIES DUE TO DAMAGE INCURRED DURING CONSTRUCTION. CONTRACTOR SHALL NOTIFY THE ENGINEER OF ANY DISCREPANCIES ON THE PLANS.

Prepared by: Matthew McHenry, March 29, 2024, 10:41:26am. K:\NA_S\160640104 - Bandera Ranch 878\CAD\Phase\160640104_ERS\160640104_ERS.dwg
 This document, together with the concepts and designs presented herein, is intended only for the specific purpose and client for which it was prepared. Reuse of and improper reliance on this document without written authorization and adaptation by Kimley-Horn and Associates, Inc. shall be without liability to Kimley-Horn and Associates, Inc.



KHA PROJECT	069401104
DATE	3/29/2024
SCALE	AS SHOWN
DESIGNED BY	ARC
DRAWN BY	ARC
CHECKED BY	MGM

**PHASE 1
EROSION
CONTROL PLAN**

BANDERA RANCH
PREPARED FOR
PARAVEL CAPITAL

REVISIONS: No. DATE BY
 HELOTES TX

KIMLEY-HORN AND ASSOCIATES, INC. 12500 WEST 40TH AVENUE, SUITE 400, DENVER, CO 80231, PHONE: (303) 751-1000, WWW.KIMLEY-HORN.COM

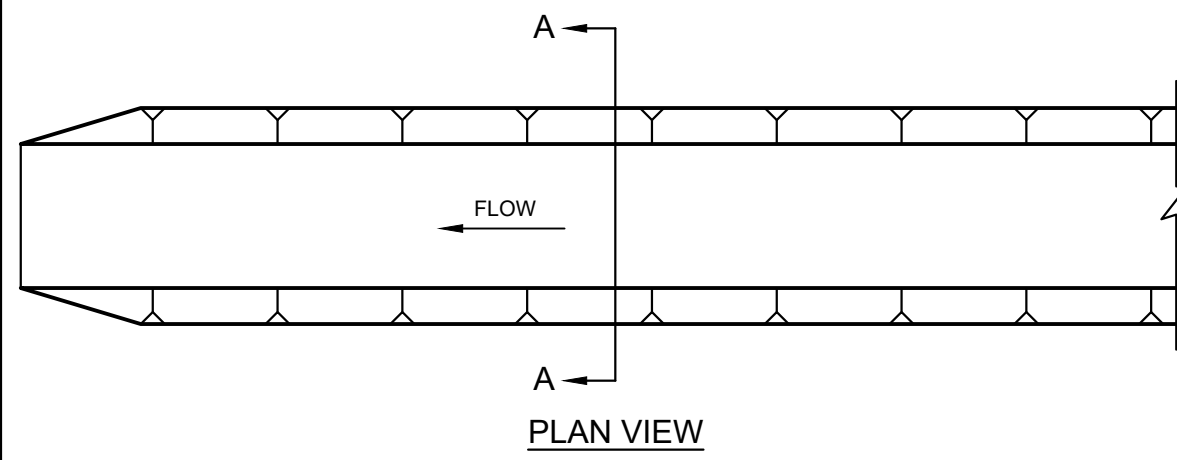

PLAN VIEW

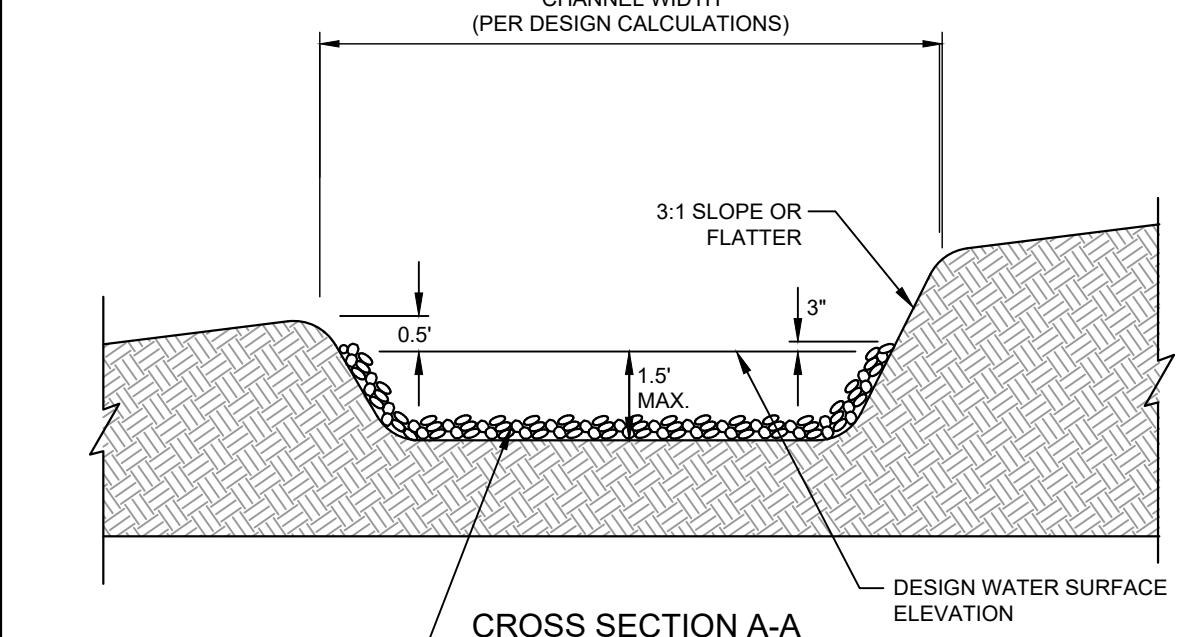

CROSS SECTION A-A

- STONE STABILIZATION MIN. 3" THICKNESS OR EROSION CONTROL MAT IS REQUIRED WHEN VELOCITIES EXCEED 6 FPS OR SLOPE EXCEEDS 2.0%
- NOTES:
1. ALL TREES, BRUSH, STUMPS, OBSTRUCTIONS AND OTHER MATERIAL SHALL BE REMOVED AND DISPOSED OF SO AS NOT TO INTERFERE WITH THE PROPER FUNCTIONING OF THE SWALE.
 2. THE SWALE SHALL BE EXCAVATED OR SHAPED TO LINE. GRADE AND CROSS-SECTION AS REQUIRED TO MEET CRITERIA SPECIFIED HEREIN AND BE FREE OF BANK PROJECTIONS OR OTHER IRREGULARITIES WHICH WILL IMPEDE NORMAL FLOW.
 3. ALL EARTH REMOVED AND NOT NEEDED IN CONSTRUCTION SHALL BE DISPOSED OF IN AN APPROVED SPILLS SITE SO THAT IT WILL NOT INTERFERE WITH THE FUNCTIONING OF THE SWALE.
 4. DIVERTED RUNOFF FROM A DISTURBED OR EXPOSED UPLAND AREA SHALL BE CONVEYED TO A SEDIMENT TRAPPING DEVICE.
 5. THE ON-SITE LOCATION MAY NEED TO BE ADJUSTED TO MEET FIELD CONDITIONS IN ORDER TO UTILIZE THE MOST SUITABLE OUTLET.
 6. STABILIZATION IS REQUIRED WHEN VELOCITIES EXCEED 6 FEET PER SECOND OR WHEN GRADES EXCEED 2.0% STABILIZATION SHALL BE CRUSHED STONE PLACED IN A LAYER OF AT LEAST 3 INCHES THICKNESS OR HIGH VELOCITY EROSION CONTROL MATTING. VEGETATION MAY BE USED FOR VELOCITIES LESS THAN 6 FEET PER SECOND.
 7. MINIMUM COMPACTION FOR THE SWALE SHALL BE 90 PERCENT STANDARD PROCTOR.

C1 INTERCEPTOR SWALE

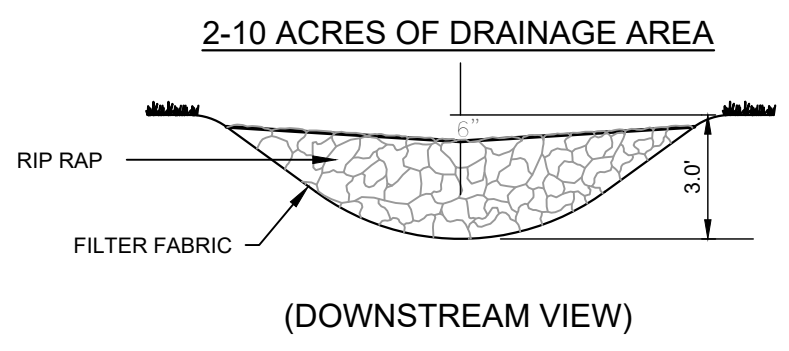

(DOWNSTREAM VIEW)

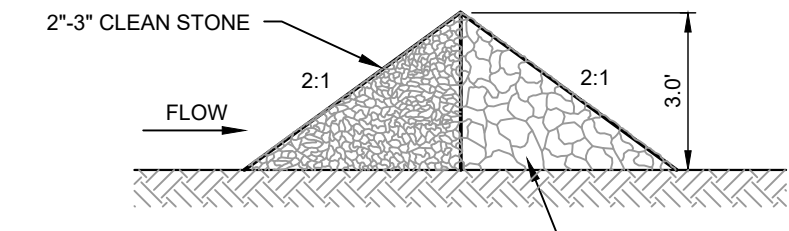

(DOWNSTREAM VIEW)



(DOWNSTREAM VIEW)

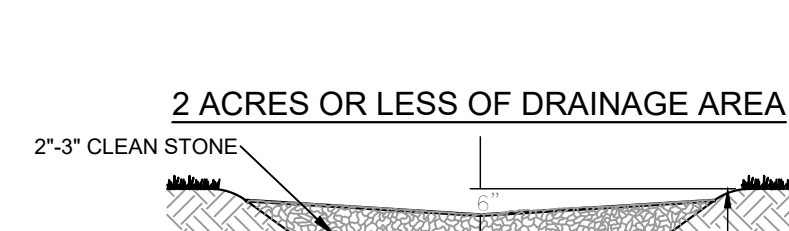

(DOWNSTREAM VIEW)



(DOWNSTREAM VIEW)

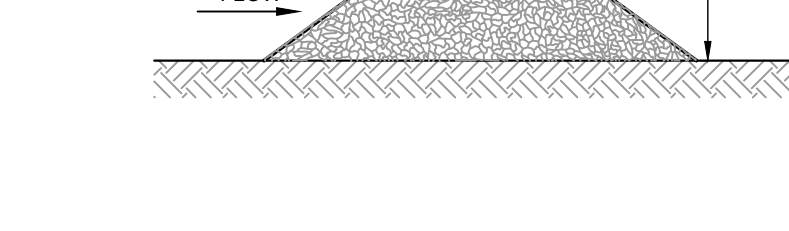

(DOWNSTREAM VIEW)

C2 ROCK CHECK DAM DETAIL

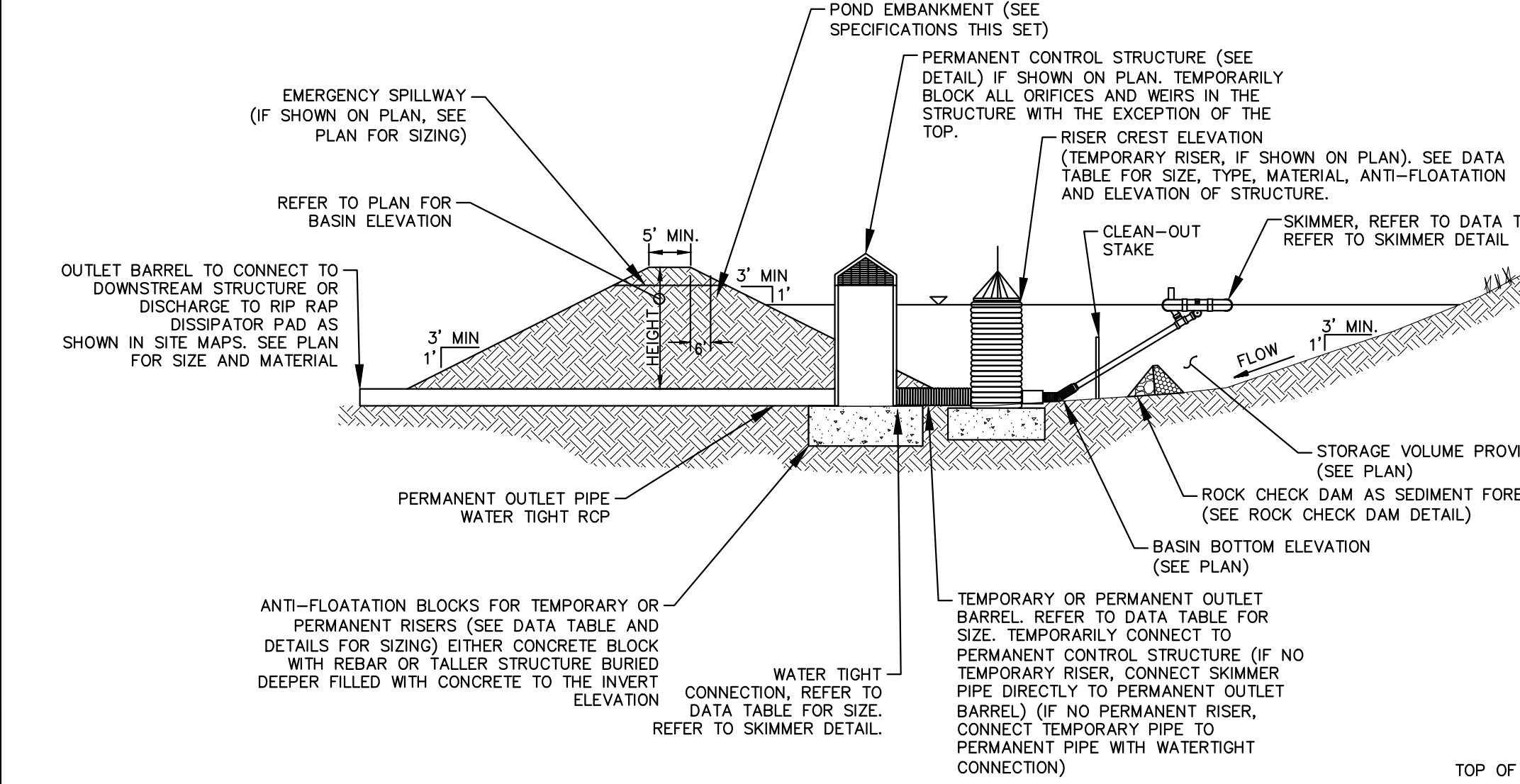

TEMPORARY SKIMMER RISER SEDIMENT BASIN WITH PIPE OUTLET

- GENERAL NOTES:
1. POND EMBANKMENTS AND ALL ASSOCIATED APPURTENANCES SHALL BE CONSTRUCTED PER THE EMBANKMENT SPECIFICATIONS ON THE STORM DRAINAGE AND POND DETAILS SHEET.
 2. REFER TO THE SKIMMER BASIN DATA TABLE THIS SHEET FOR ALL DIMENSIONS AND SIZES.
 3. ALL PIPE CONNECTIONS SHALL BE WATERTIGHT.
 4. SKIMMER SHOWN IN FLOATING POSITION.
 5. SEDIMENT BASINS MUST BE INSPECTED AND MUST BE CLEANED WHEN THE ORIGINAL CAPACITY HAS BEEN REDUCED BY 50 PERCENT OR LESS, AS REQUIRED BY GOVERNING AGENCY.
 6. ALL MATERIAL EXCAVATED FROM BEHIND SEDIMENT BARRIERS OR FROM BASINS SHALL BE INCORPORATED INTO ON-SITE SOILS OR SPREAD OUT ON AN UPLAND PORTION OF THE SITE AND STABILIZED IN SUCH A MANNER THAT IT WILL NOT ERODE.
 7. VERIFY THAT NO EROSION IS OCCURRING AT DISCHARGE POINTS TO AND FROM IMPOUNDMENTS AND VERIFY THAT BASIN SIDE SLOPES ARE STABILIZED AND SHOW NO SIGNS OF EROSION.
 8. OUTLET STRUCTURES IN SEDIMENT BASINS SHALL BE MAINTAINED IN OPERATIONAL CONDITIONS AT ALL TIMES.
 9. THE BASIN SHALL BE INSPECTED DAILY AND REPAIRS MADE AS NEEDED IN ACCORDANCE WITH THE SWPPP.
 10. CONSTRUCTION OPERATIONS SHALL BE CARRIED OUT IN SUCH A MANNER THAT EROSION AND WATER POLLUTION IS MINIMIZED.
 11. CLEANOUT STAKES SHALL BE PLACED IN ALL SEDIMENT BASINS AT THE LOW POINT IN THE BASIN. THE STAKES SHALL BE MARKED SHOWING THE HALF FULL, CLEANOUT POINT, OF THE BASIN.
 12. SAFETY FENCING 3' HIGH SHOULD BE PLACED AROUND ALL SEDIMENT BASINS.

SB SEDIMENT BASIN WITH PIPE OUTLET

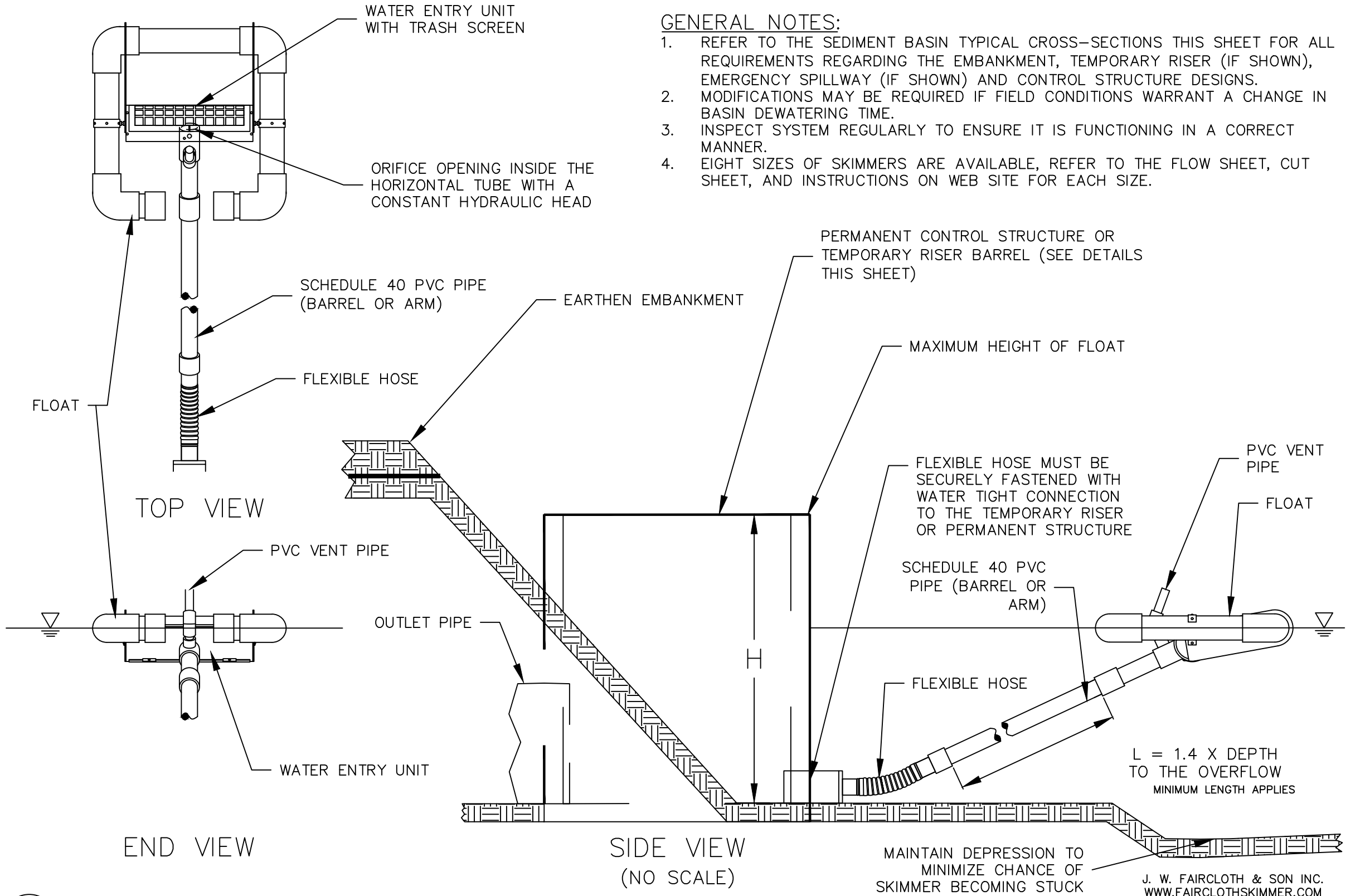

C3 FAIRCLOTH SKIMMER WITH OUTLET STRUCTURE

- GENERAL NOTES:
1. REFER TO THE SEDIMENT BASIN TYPICAL CROSS-SECTIONS THIS SHEET FOR ALL REQUIREMENTS REGARDING THE EMBANKMENT, TEMPORARY RISER (IF SHOWN), EMERGENCY SPILLWAY (IF SHOWN) AND CONTROL STRUCTURE DESIGNS. MODIFICATIONS MAY BE REQUIRED IF FIELD CONDITIONS WARRANT A CHANGE IN BASIN DEWATERING TIME.
 2. INSPECT SYSTEM REGULARLY TO ENSURE IT IS FUNCTIONING IN A CORRECT MANNER.
 3. EIGHT SIZES OF SKIMMERS ARE AVAILABLE, REFER TO THE FLOW SHEET, CUT SHEET, AND INSTRUCTIONS ON WEB SITE FOR EACH SIZE.

SITE MAP - GENERAL NOTES

1. CONTRACTOR IS SOLELY RESPONSIBLE FOR SELECTION, IMPLEMENTATION, MAINTENANCE, AND EFFECTIVENESS OF ALL SWPPP CONTROLS - CONTROLS SHOWN ON THIS SITE MAP ARE SUGGESTED CONTROLS ONLY.
2. CONTRACTOR SHALL RECORD INSTALLATION, MAINTENANCE OR MODIFICATION, AND REMOVAL DATES FOR EACH BMP EMPLOYED (WHETHER CALLED OUT ON ORIGINAL SWPPP OR NOT) DIRECTLY ON THE SITE MAP.
3. DRAINAGE PATTERNS ARE SHOWN ON THIS PLAN BY PROPOSED AND EXISTING CONTOURS, FLOW ARROWS, AND SLOPES.
4. TEMPORARY AND PERMANENT STABILIZATION PRACTICES AND BMP'S SHALL BE INSTALLED AT THE EARLIEST POSSIBLE TIME DURING THE CONSTRUCTION SEQUENCE. AS AN EXAMPLE, PERIMETER SILT FENCE SHALL BE INSTALLED BEFORE COMMENCEMENT OF ANY GRADING ACTIVITIES. OTHER BMP'S SHALL BE INSTALLED AS SOON AS PRACTICABLE AND SHALL BE MAINTAINED UNTIL FINAL SITE STABILIZATION IS ATTAINED. CONTRACTOR SHALL ALSO REFERENCE CIVIL AND LANDSCAPE PLANS SINCE PERMANENT STABILIZATION IS PROVIDED BY LANDSCAPING, THE BUILDING(S), AND SITE PAVING.
5. BMP'S HAVE BEEN LOCATED AS INDICATED ON THIS PLAN IN ACCORDANCE WITH GENERALLY ACCEPTED ENGINEERING PRACTICES IN ORDER TO MINIMIZE SEDIMENT TRANSFER. FOR EXAMPLE, SILT FENCES LOCATED AT TOE OF SLOPE AND INLET PROTECTION FOR INLETS RECEIVING SEDIMENT FROM SITE RUN-OFF.
6. SANITARY SEWER EFFLUENT IS DISPOSED OF VIA AN ONSITE SEWER SYSTEM CONNECTED TO A MUNICIPAL SEWER SYSTEM.

TEMPORARY EROSION CONTROL NOTES

1. THE CONTRACTOR SHALL INSTALL EROSION/SEDIMENTATION CONTROLS AND TREE/NATURAL AREA PROTECTIVE FENCING PRIOR TO ANY SITE PREPARATION WORK (CLEARING, GRUBBING OR EXCAVATION).
2. THE PLACEMENT OF EROSION/SEDIMENTATION CONTROLS SHALL BE IN ACCORDANCE WITH THE APPROVED EROSION AND SEDIMENTATION CONTROL PLAN.
3. THE PLACEMENT OF TREE/NATURAL AREA PROTECTIVE FENCING SHALL BE IN ACCORDANCE WITH STANDARD NOTES FOR TREE AND NATURAL AREA PROTECTION AND THE APPROVED GRADING/TREE AND NATURAL AREA PLAN.
4. A PRE-CONSTRUCTION CONFERENCE SHALL BE HELD ON-SITE WITH THE CONTRACTOR, DESIGN ENGINEER/PERMIT APPLICANT AND ENVIRONMENTAL INSPECTOR AFTER INSTALLATION OF THE EROSION/SEDIMENTATION CONTROLS AND TREE/NATURAL AREA PROTECTION MEASURES AND PRIOR TO BEGINNING ANY SITE PREPARATION WORK. THE CONTRACTOR SHALL NOTIFY THE CITY AT LEAST THREE (3) DAYS PRIOR TO THE MEETING DATE.
5. ANY MAJOR VARIATION IN MATERIALS OR LOCATIONS OF CONTROLS OR FENCES FROM THOSE SHOWN ON THE APPROVED PLANS WILL REQUIRE A REVISION AND MUST BE APPROVED BY THE REVIEWING ENGINEER, ENVIRONMENTAL SPECIALIST, OR ARBORIST AS APPROPRIATE. MAJOR REVISIONS MUST BE APPROVED BY THE PLANNING AND DEVELOPMENT DEPARTMENT AND THE DRAINAGE UTILITY DEPARTMENT. MINOR CHANGES OR ADDITIONAL CONTROL MEASURES TO BE MADE AS FIELD REVISIONS TO THE EROSION AND SEDIMENTATION CONTROL PLAN MAY BE REQUIRED BY THE ENVIRONMENTAL INSPECTOR DURING THE COURSE OF CONSTRUCTION TO CORRECT CONTROL INADEQUACIES AT NO ADDITIONAL COST TO THE OWNER.
6. THE CONTRACTOR IS REQUIRED TO INSPECT THE CONTROLS AND FENCES AT WEEKLY INTERVALS AND AFTER SIGNIFICANT RAINFALL EVENTS TO INSURE THAT THEY ARE FUNCTIONING PROPERLY. THE PERSON(S) RESPONSIBLE FOR MAINTENANCE OF CONTROLS AND FENCES SHALL IMMEDIATELY MAKE ANY NECESSARY REPAIRS TO DAMAGED AREAS. SILT ACCUMULATION AT CONTROLS MUST BE REMOVED WHEN THE DEPTH REACHES SIX (6) INCHES.

PERMANENT EROSION CONTROL NOTES

- ALL DISTURBED AREAS SHALL BE RESTORED AS NOTED BELOW.
- A. A MINIMUM OF FOUR (4) INCHES OF TOPSOIL SHALL BE PLACED IN ALL DRAINAGE CHANNELS (EXCEPT ROCK) AND BETWEEN THE CURB AND THE RIGHT-OF-WAY LINE.
 - B. THE SEEDING FOR PERMANENT EROSION CONTROL SHALL BE APPLIED OVER AREAS DISTURBED BY CONSTRUCTION AS FOLLOWS:
- BROADCAST SEEDING:
1. FROM SEPTEMBER 15 TO MARCH 1, SEEDING SHALL BE WITH A COMBINATION OF 2 POUNDS PER 1000 SQUARE FEET OF UNHULLED BERMUDA AND 7 POUNDS PER 1000 SQUARE FOOT OF WINTER RYE WITH A PURITY OF 95% WITH 90% GERMINATION.
 2. FROM MARCH 2 TO SEPTEMBER 14, SEEDING SHALL BE WITH HULLED BERMUDA AT A RATE OF 2 POUNDS PER 1000 SQUARE FEET WITH A PURITY OF 95% WITH 85% GERMINATION.
- A. FERTILIZER SHALL BE A PELLETTED OR GRANULAR SLOW RELEASE WITH AN ANALYSIS OF 15-15-15 TO BE APPLIED ONCE AT PLANTING AND ONCE DURING THE PERIOD OF ESTABLISHMENT AT THE RATE OF 1 POUND PER 1000 SQUARE FEET.
 - B. MULCH TYPE USED SHALL BE HAY, STRAW OR MULCH APPLIED AT A RATE OF 45 POUNDS PER 1000 SQUARE FEET.
- HYDRAULIC SEEDING:
1. FROM SEPTEMBER 15 TO MARCH 1, SEEDING SHALL BE WITH A COMBINATION OF 1 POUND PER 1000 SQUARE FEET OF UNHULLED BERMUDA AND 7 POUNDS PER 1000 SQUARE FOOT OF WINTER RYE WITH A PURITY OF 95% WITH 90% GERMINATION.
 2. FROM MARCH 2 TO SEPTEMBER 14, SEEDING SHALL BE WITH HULLED BERMUDA AT A RATE OF 1 POUND PER 1000 SQUARE FEET WITH A PURITY OF 95% WITH 85% GERMINATION.
- A. FERTILIZER SHALL BE A WATER SOLUBLE FERTILIZER WITH AN ANALYSIS OF 15-15-15 AT THE RATE OF 1.5 POUNDS PER 1000 SQUARE FEET.
 - B. MULCH TYPE USED SHALL BE HAY, STRAW OR MULCH APPLIED AT A RATE OF 45 POUNDS PER 1000 SQUARE FEET, WITH SOIL TACKIFIER AT A RATE OF 1.4 POUNDS PER 1000 SQUARE FEET.
 - C. THE PLANTED AREA SHALL BE IRRIGATED OR SPRINKLED IN A MANNER THAT WILL NOT ERODE THE TOPSOIL, BUT WILL SUFFICIENTLY SOAK THE SOIL TO A DEPTH OF SIX (6) INCHES. THE IRRIGATION SHALL OCCUR AT TEN-DAY INTERVALS DURING THE FIRST TWO MONTHS. RAINFALL OCCURRENCES OF 1/2 INCH OR MORE SHALL POSTPONE THE WATERING SCHEDULE FOR ONE WEEK.
 - D. RESTORATION SHALL BE ACCEPTABLE WHEN THE GRASS HAS GROWN AT LEAST 1-1/2 INCHES HIGH WITH 95% COVERAGE, PROVIDED NO BARE SPOTS LARGER THAN 16 SQUARE FEET EXIST.
 - E. WHEN REQUIRED, NATIVE GRASS SEEDING SHALL COMPLY WITH REQUIREMENTS OF THE ENVIRONMENTAL CRITERIA MANUAL.

SITE MAPS - SITE SPECIFIC NOTES

1. CONSTRUCTION ENTRANCE SHALL BE LOCATED SO AS TO PROVIDE THE LEAST AMOUNT OF DISTURBANCE TO THE FLOW OF TRAFFIC IN AND OUT OF THE SITE. ADDITIONALLY, CONSTRUCTION ENTRANCE SHALL BE LOCATED TO COINCIDE WITH THE PHASING OF THE PAVEMENT REPLACEMENT.
2. THE NATURE OF THIS SITE'S CONSTRUCTION CONSISTS OF:
 - A. CLEARING AND GRUBBING
 - B. PRELIMINARY GRADING
 - C. UTILITY INSTALLATION
 - D. PAVEMENT CONSTRUCTION
 - E. BUILDING CONSTRUCTION
 - F. FINAL GRADING AND STABILIZATION
3. THE SUBSURFACE CONDITIONS ON-SITE CONSIST GENERALLY OF A RELATIVELY THIN UPPER STRATUM OF CLAY THAT RANGES IN THICKNESS FROM 4 TO 5 INCHES, UNDERLAIN BY WEATHERED AND COMPETENT LIMESTONE ROCK, PER REPORT NO. G222838, PREPARED BY ROCK ENGINEERING AND TESTING LAB ON FEBRUARY 15, 2024.
4. STORM WATER ON-SITE WILL LEAVE THE SITE VIA SURFACE FLOW AND UNDERGROUND PIPE.
5. POST CONSTRUCTION STORM WATER POLLUTION CONTROL MEASURES INCLUDE STABILIZATION BY PERMANENT PAVING, OR LANDSCAPING.
6. VELOCITY DISSIPATION DEVICES (RIP-RAP) WILL BE USED.
7. DISTURBED PORTIONS OF SITE MUST BE STABILIZED. STABILIZATION PRACTICES MUST BE INITIATED WITHIN 14 DAYS IN PORTIONS OF THE SITE WHERE CONSTRUCTION HAS BEEN EITHER TEMPORARILY OR PERMANENTLY CEASED, UNLESS EXCEPTED WITHIN THE TPDES PERMIT. CONTRACTOR SHALL REMOVE TEMPORARY EROSION CONTROL DEVICES UPON COMPLETION OF STABILIZATION OR PERMANENT DRAINAGE FACILITIES.
8. ACCORDING TO COMMUNITY PANEL NO. 48029C0205G, DATED 9/29/2010 OF THE FEDERAL EMERGENCY MANAGEMENT AGENCY (FEMA) FLOOD INSURANCE RATE MAP (FIRM), THE TRACT IS LOCATED WITHIN ZONE "X" (UN-SHADED) DEFINED BY FEMA AS "AREAS DETERMINED TO BE OUTSIDE THE 0.2% ANNUAL CHANCE FLOODPLAIN."
9. CONTRACTOR IS RESPONSIBLE FOR MODIFYING THE SWPPP/SITE MAP TO INCLUDE BMP'S FOR ANY OFF-SITE MATERIAL WASTE, BORROW OR EQUIPMENT STORAGE AREAS.
10. CONTRACTOR SHALL INSPECT DISTURBED AREAS, MATERIAL STORAGE AREAS EXPOSED TO PRECIPITATION, STRUCTURAL CONTROL MEASURES, AND VEHICLE ENTRY AND EXIT AREAS AT LEAST ONCE EVERY 14 CALENDAR DAYS AND WITHIN 24 HOURS OF A STORM EVENT OF 0.5 INCHES OR GREATER.

Kimley-Horn
© 2024 KIMLEY-HORN AND ASSOCIATES, INC.
10101 REINING PLACE, SUITE 400, SAN ANTONIO, TX 78216
WWW.KIMLEY-HORN.COM | TBE FIRM NO. 928

STATE OF TEXAS
MATTHEW G. MATNEY
136733
Professional Engineer
03/29/2024

KHA PROJECT: 069401104
DATE: 3/29/2024
SCALE: AS SHOWN
DESIGNED BY: ARC
DRAWN BY: ARC
CHECKED BY: MCM

PHASE 1 EROSION CONTROL DETAILS

BANDERA RANCH
PREPARED FOR
PARAVEL CAPITAL

SHEET NUMBER
C2.1

1
2
3
4
5
D
C
B
A

EROSION CONTROL SCHEDULE AND SEQUENCING

I. ROUGH GRADING/ DEMOLITION	CONSTRUCTION ENTRANCE/EXIT, TREE PROTECTION, FILTER DAMS AND SILT FENCE PROTECTION SHALL BE INSTALLED PRIOR TO THE INITIATION OF ROUGH GRADING, AS NEEDED.
II. UTILITY INSTALLATION	ALL PRIOR EROSION CONTROL MEASURES INSTALLED ABOVE TO BE MAINTAINED AS NECESSARY DURING UTILITY INSTALLATION.
III. PAVING	ALL PRIOR EROSION CONTROL MEASURES INSTALLED ABOVE TO BE MAINTAINED AS NECESSARY DURING PAVING AND THROUGHOUT THE REMAINDER OF THE PROJECT.
IV. FINAL GRADING/ SOIL STABILIZATION/ LANDSCAPING	ALL TEMPORARY EROSION CONTROL MEASURES TO BE REMOVED AT THE CONCLUSION OF THE PROJECT AS DIRECTED BY THE CITY OR COUNTY.

* THE SEQUENCE OF CONSTRUCTION SHOWN ABOVE IS A GENERAL OVERVIEW AND IS INTENDED TO CONVEY THE GENERAL CONCEPTS OF THE EROSION CONTROL DESIGN AND SHOULD NOT BE RELIED UPON FOR CONSTRUCTION PURPOSES. THE CONTRACTOR IS SOLELY RESPONSIBLE FOR DETAILED PHASING AND CONSTRUCTION SEQUENCING NECESSARY TO CONSTRUCT THE PROPOSED IMPROVEMENTS INCLUDED IN THESE PLANS. THE CONTRACTOR SHALL NOTIFY ENGINEER IN WRITING IMMEDIATELY PRIOR TO AND/OR DURING CONSTRUCTION IF ANY ADDITIONAL INFORMATION ON THE CONSTRUCTION SEQUENCE IS NECESSARY. CONTRACTOR IS SOLELY RESPONSIBLE FOR COMPLYING WITH THE REQUIREMENTS OF THE AUTHORITY HAVING JURISDICTION AND ALL OTHER APPLICABLE LAWS.

SITE DATA

TOTAL LOT AREA	31.463 AC	1,370,528 SF
TOTAL AREA DISTURBED *	27.693 AC	1,206,307 SF
TOTAL PAVED AREA	3.27 AC	203,550 SF
TOTAL ROOFED AREA	4.56 AC	198,666 SF
TOTAL NEW LANDSCAPED AREA	6.50 AC	280,072 SF

* DOES NOT INCLUDE ANY OFF-SITE DISPOSAL OR BORROW AREAS - CONTRACTOR TO UPDATE AS NECESSARY DURING CONSTRUCTION.

NOTES

- AREAS CONTAINED WITHIN THE PROPERTY BOUNDARIES WILL BE AREAS OF DISTURBANCE AND SOIL STABILIZATION. ALL SOILS WITHIN THESE LIMITS SHALL BE STABILIZED BY VEGETATION OR STRUCTURE.
- REFERENCE LANDSCAPE PLANS, BY OTHERS, FOR THE TREE PRESERVATION AND MITIGATION PLAN.

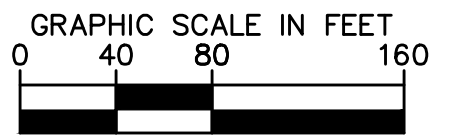
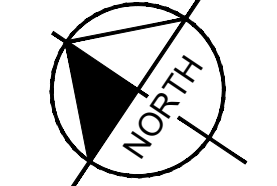

LEGEND

	PROPERTY BOUNDARY
	EXISTING CONTOUR
	PROPOSED CONTOUR
	PROPOSED LIMITS OF DISTURBANCE
	PROPOSED RETAINING WALL (TRIANGLE INDICATES FACE OF WALL)
	SILT FENCE (SEE DETAIL SHEET C3.1)
	TREE PROTECTION (SEE DETAIL SHEET C3.1)
	CONSTRUCTION EXIT (SEE DETAIL SHEET C3.1)
	PERMANENT STABILIZATION
	STONE OVERFLOW (SEE DETAIL SHEET C3.1)
	CURB INLET PROTECTION (SEE DETAIL SHEET C3.1)
	GRATE INLET PROTECTION (SEE DETAIL SHEET C3.1)
	CONCRETE WASHOUT
	ROCK BERM (SEE DETAIL SHEET C3.1)
	TREE TO REMAIN

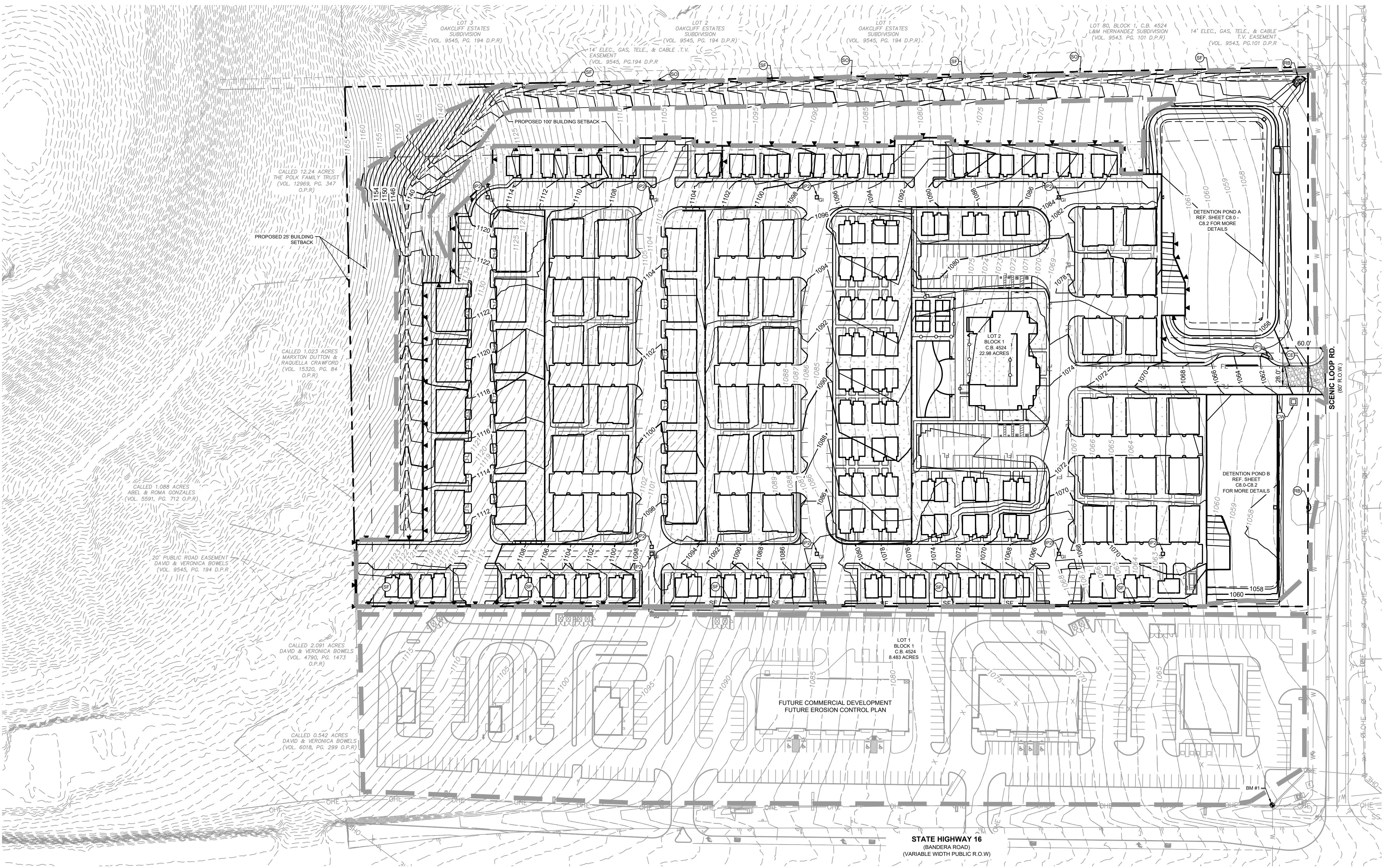

BENCHMARK LIST

BM#1	3" IRON ROD FOUND WITH YELLOW CAP MARKED "PAPE-DAWSON" AT A SOUTHWEST CORNER OF SAID 31.463 ACRE TRACT ELEVATION: 1060.00'
------	--

CAUTION!
 EXISTING UNDERGROUND UTILITIES IN THE AREA CONTRACTOR IS RESPONSIBLE FOR DETERMINING THE HORIZONTAL AND VERTICAL LOCATION OF ALL UTILITIES PRIOR TO CONSTRUCTION. CONTRACTOR SHALL BE RESPONSIBLE FOR ANY REPAIRS TO EXISTING UTILITIES DUE TO DAMAGE INCURRED DURING CONSTRUCTION. CONTRACTOR SHALL NOTIFY THE ENGINEER OF ANY DISCREPANCIES ON THE PLANS.



NO.	REVISIONS	DATE	BY

Kimley-Horn
 © 2024 KIMLEY-HORN AND ASSOCIATES, INC.
 10101 REIMOND PLACE, SUITE 400, SAN ANTONIO, TX 78216
 WWW.KIMLEY-HORN.COM | TBE FIRM NO. 928



KHA PROJECT	069401104
DATE	3/29/2024
SCALE	AS SHOWN
DESIGNED BY	ARG
DRAWN BY	ARG
CHECKED BY	MGM

**PHASE 2
 EROSION
 CONTROL PLAN**

**BANDERA RANCH
 PREPARED FOR
 PARAVEL CAPITAL**

**ATTACHMENT H – TEMPORARY SEDIMENT POND(S) PLANS AND
CALCULATIONS**

(Not applicable)

ATTACHMENT I – Inspection and Maintenance for BMPs

The following are guidelines for the overall maintenance of the detention basin associated with the Bandera Ranch project.

Maintenance on Batch Detention Basins

Regular, routine maintenance is essential to effective, long-lasting performance of batch detention basins. Neglect or failure to service the filters regularly will lead to poor performance and eventual costly repairs. It is recommended that batch detention basins be inspected at a minimum of twice a year. The first inspection should occur after the first indications of wet weather to ensure the requirements are being met. The remaining inspections shall occur in between storm events. Debris and sediment shall be removed if found in the level sensor, orifice, and outlet(s).

Indications of the need for maintenance:

- Clogging in the outlet or trash screen
- Damage to the structural elements of the system

Other recommended maintenance guidelines include:

- *Sediment Removal.* Remove sediment from the basin at least every 5 years or when the sediment depth is greater than 6 inches. Sediment should be cleared when the sediment intervenes with the level sensor or if the basin has not drained within 48 hours.
- *Debris and Litter Removal.* Debris and litter will accumulate near the sedimentation basin outlet device and should be removed during regular mowing operations and inspections at least twice a year. Particular attention should be paid to floating debris that can eventually clog the control device or riser and be removed at once.
- *Structural Repairs and Replacement.* Damage to the structural elements of the basin shall be inspected, identified, and repaired immediately if needed.
- *Mowing.* Grass areas in and around the batch detention basin must be mowed to limit vegetation height to 18 inches. More frequent mowing to maintain aesthetic appeal may be necessary in landscaped areas.

ATTACHMENT J – Schedule of Interim and Permanent Soil Stabilization Practices

Stabilization measures shall be initiated as soon as possible in portions of the site where construction activities have ceased, temporarily or permanently, but in no case more than 14 days after the construction activity in that portion of the site concluded. Where the initiation of stabilization measures by the 14th day after construction activity temporary or permanently ceases is precluded by weather conditions, stabilization measures shall be initiated as soon as practicable. Where construction activity on a portion of the site is temporarily ceased, and earth-disturbing activities will be resumed within 21 days, temporary stabilization measures do not have to be initiated on that portion of the site. In areas experiencing droughts where the initiation of stabilization measures by the 14th day after construction activity has temporarily or permanently ceased is precluded by seasonal arid conditions, stabilization measures shall be initiated as soon as practicable.

SOIL STABILIZATION PRACTICES:

- HYDROMULCHING
- TEMPORARY SEEDING
- PERMANENT PLANTING, SODDING, OR SEEDING
- MULCHING
- SOIL RETENTION BLANKET
- BUFFER ZONES
- PRESERVATION OF NATURAL RESOURCES

OTHER: Disturbed areas, in which construction activity has ceased temporarily or permanently, shall be stabilized within 14 days unless activities are scheduled to resume and done within 21 days.



Notice of Intent (NOI) for an Authorization for Stormwater Discharges Associated with Construction Activity under TPDES General Permit TXR150000

IMPORTANT INFORMATION

Please read and use the General Information and Instructions prior to filling out each question in the NOI form.

Use the NOI Checklist to ensure all required information is completed correctly.

Incomplete applications delay approval or result in automatic denial.

Once processed your permit authorization can be viewed by entering the following link into your internet browser: http://www2.tceq.texas.gov/wq_dpa/index.cfm or you can contact TCEQ Stormwater Processing Center at 512-239-3700.

ePERMITS

Effective September 1, 2018, this paper form must be submitted to TCEQ with a completed electronic reporting waiver form (TCEQ-20754).

To submit an NOI electronically, enter the following web address into your internet browser and follow the instructions: <https://www3.tceq.texas.gov/steers/index.cfm>

APPLICATION FEE AND PAYMENT

The application fee for submitting a paper NOI is \$325. The application fee for electronic submittal of a NOI through the TCEQ ePermits system (STEERS) is \$225.

Payment of the application fee can be submitted by mail or through the TCEQ ePay system. The payment and the NOI must be mailed to separate addresses. To access the TCEQ ePay system enter the following web address into your internet browser:
<http://www.tceq.texas.gov/epay>.

Provide your payment information for verification of payment:

- If payment was mailed to TCEQ, provide the following:
 - Check/Money Order Number:
 - Name printed on Check:
- If payment was made via ePay, provide the following:
 - Voucher Number:
 - A copy of the payment voucher is attached to this paper NOI form.

RENEWAL (This portion of the NOI is not applicable after June 3, 2018)

Is this NOI for a renewal of an existing authorization? Yes No

If Yes, provide the authorization number here: TXR15 [REDACTED]

NOTE: If an authorization number is not provided, a new number will be assigned.

SECTION 1. OPERATOR (APPLICANT)

a) If the applicant is currently a customer with TCEQ, what is the Customer Number (CN) issued to this entity? CN CN606209005

(Refer to Section 1.a) of the Instructions)

b) What is the Legal Name of the entity (applicant) applying for this permit? (The legal name must be spelled exactly as filed with the Texas Secretary of State, County, or in the legal document forming the entity.)

Helotes Bandera Ranch, LP

c) What is the contact information for the Operator (Responsible Authority)?

Prefix (Mr. Ms. Miss): Mr.

First and Last Name: Curtis Thigpen Suffix: [REDACTED]

Title: Owner Credentials: [REDACTED]

Phone Number: 512-934-8293 Fax Number: [REDACTED]

E-mail: cthigpen@paravelcap.com

Mailing Address: 1509 Old West 38th St., Suite 3

City, State, and Zip Code: Austin, TX 78731

Mailing Information if outside USA:

Territory: [REDACTED]

Country Code: [REDACTED] Postal Code: [REDACTED]

d) Indicate the type of customer:

- | | |
|---|---|
| <input type="checkbox"/> Individual | <input type="checkbox"/> Federal Government |
| <input checked="" type="checkbox"/> Limited Partnership | <input type="checkbox"/> County Government |
| <input type="checkbox"/> General Partnership | <input type="checkbox"/> State Government |
| <input type="checkbox"/> Trust | <input type="checkbox"/> City Government |
| <input type="checkbox"/> Sole Proprietorship (D.B.A.) | <input type="checkbox"/> Other Government |
| <input type="checkbox"/> Corporation | <input type="checkbox"/> Other: [REDACTED] |
| <input type="checkbox"/> Estate | |

e) Is the applicant an independent operator? Yes No

(If a governmental entity, a subsidiary, or part of a larger corporation, check No.)

f) Number of Employees. Select the range applicable to your company.

0-20

251-500

21-100

501 or higher

101-250

g) Customer Business Tax and Filing Numbers: (**Required** for Corporations and Limited Partnerships. **Not Required** for Individuals, Government, or Sole Proprietors.)

State Franchise Tax ID Number: 32086461731

Federal Tax ID: 92-0836859

Texas Secretary of State Charter (filing) Number: 0804747721

DUNS Number (if known): 110813049

SECTION 2. APPLICATION CONTACT

Is the application contact the same as the applicant identified above?

Yes, go to Section 3

No, complete this section

Prefix (Mr. Ms. Miss): Mr.

First and Last Name: Matthew G. Matney Suffix: [REDACTED]

Title: Project Manager Credential: P.E.

Organization Name: Kimley-Horn and Associates, Inc.

Phone Number: 210-321-3419 Fax Number: [REDACTED]

E-mail: matthew.matney@kimley-horn.com

Mailing Address: 10101 Reunion Place, Suite 400

Internal Routing (Mail Code, Etc.): [REDACTED]

City, State, and Zip Code: San Antonio, TX 78216

Mailing information if outside USA:

Territory: [REDACTED]

Country Code: [REDACTED]

Postal Code: [REDACTED]

SECTION 3. REGULATED ENTITY (RE) INFORMATION ON PROJECT OR SITE

a) If this is an existing permitted site, what is the Regulated Entity Number (RN) issued to this site? RN RN111858122

(Refer to Section 3.a) of the Instructions)

- b) Name of project or site (the name known by the community where it's located): Bandera Ranch
- c) In your own words, briefly describe the type of construction occurring at the regulated site (residential, industrial, commercial, or other): Multi-Family Development & Commercial Development
- d) County or Counties (if located in more than one): Bexar County
- e) Latitude: 29°35'3.23"W Longitude: 98°41'31.56"W
- f) Site Address/Location

If the site has a physical address such as 12100 Park 35 Circle, Austin, TX 78753, complete *Section A*.

If the site does not have a physical address, provide a location description in *Section B*. Example: located on the north side of FM 123, 2 miles west of the intersection of FM 123 and Highway 1.

Section A:

Street Number and Name: 15030 Bandera Road

City, State, and Zip Code: Helotes, TX 78023

Section B:

Location Description:

City (or city nearest to) where the site is located:

Zip Code where the site is located:

SECTION 4. GENERAL CHARACTERISTICS

- a) Is the project or site located on Indian Country Lands?
 - Yes, do not submit this form. You must obtain authorization through EPA Region 6.
 - No
- b) Is your construction activity associated with a facility that, when completed, would be associated with the exploration, development, or production of oil or gas or geothermal resources?
 - Yes. Note: The construction stormwater runoff may be under jurisdiction of the Railroad Commission of Texas and may need to obtain authorization through EPA Region 6.
 - No
- c) What is the Primary Standard Industrial Classification (SIC) Code that best describes the construction activity being conducted at the site? 1522
- d) What is the Secondary SIC Code(s), if applicable? 1542
- e) What is the total number of acres to be disturbed? 31.463
- f) Is the project part of a larger common plan of development or sale?

Yes

No. The total number of acres disturbed, provided in e) above, must be 5 or more. If the total number of acres disturbed is less than 5, do not submit this form. See the requirements in the general permit for small construction sites.

g) What is the estimated start date of the project? 10/2024

h) What is the estimated end date of the project? 10/2028

i) Will concrete truck washout be performed at the site? Yes No

j) What is the name of the first water body(ies) to receive the stormwater runoff or potential runoff from the site? Helotes Creek

k) What is the segment number(s) of the classified water body(ies) that the discharge will eventually reach? 1906A

l) Is the discharge into a Municipal Separate Storm Sewer System (MS4)?

Yes No

If Yes, provide the name of the MS4 operator: City of Helotes

Note: The general permit requires you to send a copy of this NOI form to the MS4 operator.

m) Is the discharge or potential discharge from the site within the Recharge Zone, Contributing Zone, or Contributing Zone within the Transition Zone of the Edwards Aquifer, as defined in 30 TAC Chapter 213?

Yes, complete the certification below.

No, go to Section 5

I certify that the copy of the TCEQ-approved Plan required by the Edwards Aquifer Rule (30 TAC Chapter 213) that is included or referenced in the Stormwater Pollution Prevention Plan will be implemented. Yes

SECTION 5. NOI CERTIFICATION

a) I certify that I have obtained a copy and understand the terms and conditions of the Construction General Permit (TXR150000). Yes

b) I certify that the full legal name of the entity applying for this permit has been provided and is legally authorized to do business in Texas. Yes

c) I understand that a Notice of Termination (NOT) must be submitted when this authorization is no longer needed. Yes

d) I certify that a Stormwater Pollution Prevention Plan has been developed, will be implemented prior to construction and to the best of my knowledge and belief is compliant with any applicable local sediment and erosion control plans, as required in the Construction General Permit (TXR150000). Yes

Note: For multiple operators who prepare a shared SWP3, the confirmation of an operator may be limited to its obligations under the SWP3, provided all obligations are confirmed by at least one operator.

SECTION 6. APPLICANT CERTIFICATION SIGNATURE

Operator Signatory Name: Curtis Thigpen

Operator Signatory Title: Owner

I certify under penalty of law that this document and all attachments were prepared under my direction or supervision in accordance with a system designed to assure that qualified personnel properly gather and evaluate the information submitted. Based on my inquiry of the person or persons who manage the system, or those persons directly responsible for gathering the information, the information submitted is, to the best of my knowledge and belief, true, accurate, and complete. I am aware there are significant penalties for submitting false information, including the possibility of fine and imprisonment for knowing violations.

I further certify that I am authorized under 30 Texas Administrative Code §305.44 to sign and submit this document, and can provide documentation in proof of such authorization upon request.

Signature (use blue ink):



Date: 3-29-24

NOTICE OF INTENT CHECKLIST (TXR150000)

Did you complete everything? Use this checklist to be sure!

Are you ready to mail your form to TCEQ? Go to the General Information Section of the Instructions for mailing addresses.

Confirm each item (or applicable item) in this form is complete. This checklist is for use by the applicant to ensure a complete application is being submitted. **Missing information may result in denial of coverage under the general permit.** (See NOI process description in the General Information and Instructions.)

APPLICATION FEE

If paying by check:

- Check was mailed **separately** to the TCEQs Cashier's Office. (See Instructions for Cashier's address and Application address.)
- Check number and name on check is provided in this application.

If using ePay:

- The voucher number is provided in this application and a copy of the voucher is attached.

RENEWAL

- If this application is for renewal of an existing authorization, the authorization number is provided.

OPERATOR INFORMATION

- Customer Number (CN) issued by TCEQ Central Registry
- Legal name as filed to do business in Texas. (Call TX SOS 512-463-5555 to verify.)
- Name and title of responsible authority signing the application.
- Phone number and e-mail address
- Mailing address is complete & verifiable with USPS. www.usps.com
- Type of operator (entity type). Is applicant an independent operator?
- Number of employees.
- For corporations or limited partnerships - Tax ID and SOS filing numbers.
- Application contact and address is complete & verifiable with USPS. <http://www.usps.com>

REGULATED ENTITY (RE) INFORMATION ON PROJECT OR SITE

- Regulated Entity Number (RN) (if site is already regulated by TCEQ)
- Site/project name and construction activity description
- County
- Latitude and longitude <http://www.tceq.texas.gov/gis/sqmaview.html>

Site Address/Location. Do not use a rural route or post office box.

GENERAL CHARACTERISTICS

- Indian Country Lands -the facility is not on Indian Country Lands.
- Construction activity related to facility associated to oil, gas, or geothermal resources
- Primary SIC Code that best describes the construction activity being conducted at the site. www.osha.gov/oshstats/sicser.html
- Estimated starting and ending dates of the project.
- Confirmation of concrete truck washout.
- Acres disturbed is provided and qualifies for coverage through a NOI.
- Common plan of development or sale.
- Receiving water body or water bodies.
- Segment number or numbers.
- MS4 operator.
- Edwards Aquifer rule.

CERTIFICATION

- Certification statements have been checked indicating Yes.
- Signature meets 30 Texas Administrative Code (TAC) §305.44 and is original.

Instructions for Notice of Intent (NOI) for Stormwater Discharges Associated with Construction Activity under TPDES General Permit (TXR150000)

GENERAL INFORMATION

Where to Send the Notice of Intent (NOI):

By Regular Mail:

TCEQ

Stormwater Processing Center (MC228)

P.O. Box 13087

Austin, Texas 78711-3087

By Overnight or Express Mail:

TCEQ

Stormwater Processing Center (MC228)

12100 Park 35 Circle

Austin, TX

Application Fee:

The application fee of \$325 is required to be paid at the time the NOI is submitted. Failure to submit payment at the time the application is filed will cause delays in acknowledgment or denial of coverage under the general permit. Payment of the fee may be made by check or money order, payable to TCEQ, or through EPAY (electronic payment through the web).

Mailed Payments:

Use the attached General Permit Payment Submittal Form. The application fee is submitted to a different address than the NOI. Read the General Permit Payment Submittal Form for further instructions, including the address to send the payment.

ePAY Electronic Payment: <http://www.tceq.texas.gov/epay>

When making the payment you must select Water Quality, and then select the fee category "General Permit Construction Storm Water Discharge NOI Application". You must include a copy of the payment voucher with your NOI. Your NOI will not be considered complete without the payment voucher.

TCEQ Contact List:

Application – status and form questions:

512-239-3700, swpermit@tceq.texas.gov

Technical questions:

512-239-4671, swgp@tceq.texas.gov

Environmental Law Division:

512-239-0600

Records Management - obtain copies of forms:

512-239-0900

Reports from databases (as available):

512-239-DATA (3282)

Cashier's office:

512-239-0357 or 512-239-0187

Notice of Intent Process:

When your NOI is received by the program, the form will be processed as follows:

- **Administrative Review:** Each item on the form will be reviewed for a complete response. In addition, the operator's legal name must be verified with Texas Secretary of State as valid and active (if applicable). The address(es) on the form must be verified with the US Postal service as receiving regular mail delivery. Do not give an overnight/express mailing address.

- **Notice of Deficiency:** If an item is incomplete or not verifiable as indicated above, a notice of deficiency (NOD) will be mailed to the operator. The operator will have 30 days to respond to the NOD. The response will be reviewed for completeness.
- **Acknowledgment of Coverage:** An Acknowledgment Certificate will be mailed to the operator. This certificate acknowledges coverage under the general permit.

or

Denial of Coverage: If the operator fails to respond to the NOD or the response is inadequate, coverage under the general permit may be denied. If coverage is denied, the operator will be notified.

General Permit (Your Permit)

For NOIs submitted **electronically** through ePermits, provisional coverage under the general permit begins immediately following confirmation of receipt of the NOI form by the TCEQ.

For **paper** NOIs, provisional coverage under the general permit begins **7 days after a completed NOI is postmarked for delivery** to the TCEQ.

You should have a copy of your general permit when submitting your application. You may view and print your permit for which you are seeking coverage, on the TCEQ web site <http://www.tceq.texas.gov>. Search using keyword TXR150000.

Change in Operator

An authorization under the general permit is not transferable. If the operator of the regulated project or site changes, the present permittee must submit a Notice of Termination and the new operator must submit a Notice of Intent. The NOT and NOI must be submitted no later than 10 days prior to the change in Operator status.

TCEQ Central Registry Core Data Form

The Core Data Form has been incorporated into this form. Do not send a Core Data Form to TCEQ. After final acknowledgment of coverage under the general permit, the program will assign a Customer Number and Regulated Entity Number, if one has not already been assigned to this customer or site.

For existing customers and sites, you can find the Customer Number and Regulated Entity Number by entering the following web address into your internet browser: <http://www15.tceq.texas.gov/crpub/> or you can contact the TCEQ Stormwater Processing Center at 512-239-3700 for assistance. On the website, you can search by your permit number, the Regulated Entity (RN) number, or the Customer Number (CN). If you do not know these numbers, you can select “Advanced Search” to search by permittee name, site address, etc.

The Customer (Permittee) is responsible for providing consistent information to the TCEQ, and for updating all CN and RN data for all authorizations as changes occur. For this permit, a Notice of Change form must be submitted to the program area.

INSTRUCTIONS FOR FILLING OUT THE NOI FORM

Renewal of General Permit. Dischargers holding active authorizations under the expired General Permit are required to submit a NOI to continue coverage. The existing permit number is required. If the permit number is not provided or has been terminated, expired, or denied, a new permit number will be issued.

Section 1. OPERATOR (APPLICANT)

a) Customer Number (CN)

TCEQ's Central Registry will assign each customer a number that begins with CN, followed by nine digits. **This is not a permit number, registration number, or license number.**

If the applicant is an existing TCEQ customer, the Customer Number is available at the following website: <http://www15.tceq.texas.gov/crpub/>. If the applicant is not an existing TCEQ customer, leave the space for CN blank.

b) Legal Name of Applicant

Provide the current legal name of the applicant. The name must be provided exactly as filed with the Texas Secretary of State (SOS), or on other legal documents forming the entity, as filed in the county. You may contact the SOS at 512-463-5555, for more information related to filing in Texas. If filed in the county, provide a copy of the legal documents showing the legal name.

c) Contact Information for the Applicant (Responsible Authority)

Provide information for the person signing the application in the Certification section. This person is also referred to as the Responsible Authority.

Provide a complete mailing address for receiving mail from the TCEQ. The mailing address must be recognized by the US Postal Service. You may verify the address on the following website: <https://tools.usps.com/go/ZipLookupAction!input.action>.

The phone number should provide contact to the applicant.

The fax number and e-mail address are optional and should correspond to the applicant.

d) Type of Customer (Entity Type)

Check only one box that identifies the type of entity. Use the descriptions below to identify the appropriate entity type. Note that the selected entity type also indicates the name that must be provided as an applicant for an authorization.

Individual

An individual is a customer who has not established a business, but conducts an activity that needs to be regulated by the TCEQ.

Partnership

A customer that is established as a partnership as defined by the Texas Secretary of State Office (TX SOS). If the customer is a 'General Partnership' or 'Joint Venture' filed in the county (not filed with TX SOS), the legal name of each partner forming the 'General Partnership' or 'Joint Venture' must be provided. Each 'legal entity' must apply as a co-applicant.

Trust or Estate

A trust and an estate are fiduciary relationships governing the trustee/executor with respect to the trust/estate property.

Sole Proprietorship (DBA)

A sole proprietorship is a customer that is owned by only one person and has not been incorporated. This business may:

1. be under the person's name
2. have its own name (doing business as or DBA)
3. have any number of employees.

If the customer is a Sole Proprietorship or DBA, the 'legal name' of the individual business 'owner' must be provided. The DBA name is not recognized as the 'legal name' of the entity. The DBA name may be used for the site name (regulated entity).

Corporation

A customer that meets all of these conditions:

1. is a legally incorporated entity under the laws of any state or country
2. is recognized as a corporation by the Texas Secretary of State
3. has proper operating authority to operate in Texas

The corporation's 'legal name' as filed with the Texas Secretary of State must be provided as applicant. An 'assumed' name of a corporation is not recognized as the 'legal name' of the entity.

Government

Federal, state, county, or city government (as appropriate)

The customer is either an agency of one of these levels of government or the governmental body itself. The government agency's 'legal name' must be provided as the applicant. A department name or other description of the organization is not recognized as the 'legal name'.

Other

This may include a utility district, water district, tribal government, college district, council of governments, or river authority. Provide the specific type of government.

e) Independent Entity

Check No if this customer is a subsidiary, part of a larger company, or is a governmental entity. Otherwise, check Yes.

f) Number of Employees

Check one box to show the number of employees for this customer's entire company, at all locations. This is not necessarily the number of employees at the site named in the application.

g) Customer Business Tax and Filing Numbers

These are required for Corporations and Limited Partnerships. These are not required for Individuals, Government, and Sole Proprietors.

State Franchise Tax ID Number

Corporations and limited liability companies that operate in Texas are issued a franchise tax identification number. If this customer is a corporation or limited liability company, enter the Tax ID number.

Federal Tax ID

All businesses, except for some small sole proprietors, individuals, or general partnerships should have a federal taxpayer identification number (TIN). Enter this number here. Use no prefixes, dashes, or hyphens. Sole proprietors, individuals, or general partnerships do not need to provide a federal tax ID.

TX SOS Charter (filing) Number

Corporations and Limited Partnerships required to register with the Texas Secretary of State are issued a charter or filing number. You may obtain further information by calling SOS at 512-463-5555.

DUNS Number

Most businesses have a DUNS (Data Universal Numbering System) number issued by Dun and Bradstreet Corp. If this customer has one, enter it here.

Section 2. APPLICATION CONTACT

Provide the name and contact information for the person that TCEQ can contact for additional information regarding this application.

Section 3. REGULATED ENTITY (RE) INFORMATION ON PROJECT OR SITE

a) Regulated Entity Number (RN)

The RN is issued by TCEQ's Central Registry to sites where an activity is regulated by TCEQ. This is not a permit number, registration number, or license number. Search TCEQ's Central Registry to see if the site has an assigned RN at <http://www15.tceq.texas.gov/crpub/>. If this regulated entity has not been assigned an RN, leave this space blank.

If the site of your business is part of a larger business site, an RN may already be assigned for the larger site. Use the RN assigned for the larger site.

If the site is found, provide the assigned RN and provide the information for the site to be authorized through this application. The site information for this authorization may vary from the larger site information.

An example is a chemical plant where a unit is owned or operated by a separate corporation that is accessible by the same physical address of your unit or facility. Other examples include industrial parks identified by one common address but different corporations have control of defined areas within the site. In both cases, an RN would be assigned for the physical address location and the permitted sites would be identified separately under the same RN.

b) Name of the Project or Site

Provide the name of the site or project as known by the public in the area where the site is located. The name you provide on this application will be used in the TCEQ Central Registry as the Regulated Entity name.

c) Description of Activity Regulated

In your own words, briefly describe the primary business that you are doing that requires this authorization. Do not repeat the SIC Code description.

d) County

Provide the name of the county where the site or project is located. If the site or project is located in more than one county, provide the county names as secondary.

e) Latitude and Longitude

Enter the latitude and longitude of the site in degrees, minutes, and seconds or decimal form. For help obtaining the latitude and longitude, go to:

<http://www.tceq.texas.gov/gis/sqmaview.html>.

f) Site Address/Location

If a site has an address that includes a street number and street name, enter the complete address for the site in *Section A*. If the physical address is not recognized as a USPS delivery address, you may need to validate the address with your local police (911 service) or through an online map site used to locate a site. Please confirm this to be a complete and valid address. Do not use a rural route or post office box for a site location.

If a site does not have an address that includes a street number and street name, provide a complete written location description in *Section B*. For example: "The site is located on the north side of FM 123, 2 miles west of the intersection of FM 123 and Highway 1."

Provide the city (or nearest city) and zip code of the site location.

Section 4. GENERAL CHARACTERISTICS

a) Indian Country Lands

If your site is located on Indian Country Lands, the TCEQ does not have authority to process your application. You must obtain authorization through EPA Region 6, Dallas. Do not submit this form to TCEQ.

b) Construction activity associated with facility associated with exploration, development, or production of oil, gas, or geothermal resources

If your activity is associated with oil and gas exploration, development, or production, you may be under jurisdiction of the Railroad Commission of Texas (RRC) and may need to obtain authorization from EPA Region 6.

Construction activities associated with a facility related to oil, gas or geothermal resources may include the construction of a well site; treatment or storage facility; underground hydrocarbon or natural gas storage facility; reclamation plant; gas processing facility; compressor station; terminal facility where crude oil is stored prior to refining and at which refined products are stored solely for use at the facility; a

carbon dioxide geologic storage facility; and a gathering, transmission, or distribution pipeline that will transport crude oil or natural gas, including natural gas liquids, prior to refining of such oil or the use of the natural gas in any manufacturing process or as a residential or industrial fuel.

Where required by federal law, discharges of stormwater associated with construction activities under the RRC's jurisdiction must be authorized by the EPA and the RRC, as applicable. Activities under RRC jurisdiction include construction of a facility that, when completed, would be associated with the exploration, development, or production of oil or gas or geothermal resources, such as a well site; treatment or storage facility; underground hydrocarbon or natural gas storage facility; reclamation plant; gas processing facility; compressor station; terminal facility where crude oil is stored prior to refining and at which refined products are stored solely for use at the facility; a carbon dioxide geologic storage facility under the jurisdiction of the RRC; and a gathering, transmission, or distribution pipeline that will transport crude oil or natural gas, including natural gas liquids, prior to refining of such oil or the use of the natural gas in any manufacturing process or as a residential or industrial fuel. The RRC also has jurisdiction over stormwater from land disturbance associated with a site survey that is conducted prior to construction of a facility that would be regulated by the RRC. Under 33 U.S.C. §1342(l)(2) and §1362(24), EPA cannot require a permit for discharges of stormwater from field activities or operations associated with {oil and gas} exploration, production, processing, or treatment operations, or transmission facilities, including activities necessary to prepare a site for drilling and for the movement and placement of drilling equipment, whether or not such field activities or operations may be considered to be construction activities unless the discharge is contaminated by contact with any overburden, raw material, intermediate product, finished product, byproduct, or waste product located on the site of the facility. Under §3.8 of this title (relating to Water Protection), the RRC prohibits operators from causing or allowing pollution of surface or subsurface water. Operators are encouraged to implement and maintain best management practices (BMPs) to minimize discharges of pollutants, including sediment, in stormwater during construction activities to help ensure protection of surface water quality during storm events.

For more information about the jurisdictions of the RRC and the TCEQ, read the Memorandum of Understanding (MOU) between the RRC and TCEQ at 16 Texas Administrative Code, Part 1, Chapter 3, Rule 3.30, by entering the following link into an internet browser:

[http://texreg.sos.state.tx.us/public/readtac\\$ext.TacPage?sl=R&app=9&p_dir=&p_rloc=&p_tloc=&p_ploc=&pg=1&p_tac=&ti=16&pt=1&ch=3&rl=30](http://texreg.sos.state.tx.us/public/readtac$ext.TacPage?sl=R&app=9&p_dir=&p_rloc=&p_tloc=&p_ploc=&pg=1&p_tac=&ti=16&pt=1&ch=3&rl=30) or contact the TCEQ Stormwater Team at 512-239-4671 for additional information.

c) Primary Standard Industrial Classification (SIC) Code

Provide the SIC Code that best describes the construction activity being conducted at this site.

Common SIC Codes related to construction activities include:

- 1521 - Construction of Single Family Homes
- 1522 - Construction of Residential Buildings Other than Single Family Homes
- 1541 - Construction of Industrial Buildings and Warehouses

- 1542 - Construction of Non-residential Buildings, other than Industrial Buildings and Warehouses
- 1611 - Highway and Street Construction, except Highway Construction
- 1622 - Bridge, Tunnel, and Elevated Highway Construction
- 1623 - Water, Sewer, Pipeline and Communications, and Power Line Construction

For help with SIC Codes, enter the following link into your internet browser: <http://www.osha.gov/pls/imis/sicsearch.html> or you can contact the TCEQ Small Business and Local Government Assistance Section at 800-447-2827 for assistance.

d) Secondary SIC Code

Secondary SIC Code(s) may be provided. Leave this blank if not applicable. For help with SIC Codes, enter the following link into your internet browser: <http://www.osha.gov/pls/imis/sicsearch.html> or you can contact the TCEQ Small Business and Environmental Assistance Section at 800-447-2827 for assistance.

e) Total Number of Acres Disturbed

Provide the approximate number of acres that the construction site will disturb. Construction activities that disturb less than one acre, unless they are part of a larger common plan that disturbs more than one acre, do not require permit coverage. Construction activities that disturb between one and five acres, unless they are part of a common plan that disturbs more than five acres, do not require submission of an NOI. Therefore, the estimated area of land disturbed should not be less than five, unless the project is part of a larger common plan that disturbs five or more acres. Disturbed means any clearing, grading, excavating, or other similar activities.

If you have any questions about this item, please contact the stormwater technical staff by phone at 512-239-4671 or by email at swgp@tceq.texas.gov.

f) Common Plan of Development

Construction activities that disturb less than five acres do not require submission of an NOI unless they are part of a common plan of development or for sale where the area disturbed is five or more acres. Therefore, the estimated area of land disturbed should not be less than five, unless the project is part of a larger common plan that disturbs five or more acres. Disturbed means any clearing, grading, excavating, or other similar activities.

For more information on what a common plan of development is, refer to the definition of “Common Plan of Development” in the Definitions section of the general permit or enter the following link into your internet browser: www.tceq.texas.gov/permitting/stormwater/common_plan_of_development_steps.html

For further information, go to the TCEQ stormwater construction webpage enter the following link into your internet browser: www.tceq.texas.gov/goto/construction and search for “Additional Guidance and Quick Links”. If you have any further questions about the Common Plan of Development you can contact the TCEQ Stormwater Team at 512-239-4671 or the TCEQ Small Business and Environmental Assistance at 800-447-2827.

g) Estimated Start Date of the Project

This is the date that any construction activity or construction support activity is initiated at the site. If renewing the permit provide the original start date of when construction activity for this project began.

h) Estimated End Date of the Project

This is the date that any construction activity or construction support activity will end and final stabilization will be achieved at the site.

i) Will concrete truck washout be performed at the site?

Indicate if you expect that operators of concrete trucks will washout concrete trucks at the construction site.

j) Identify the water body(s) receiving stormwater runoff

The stormwater may be discharged directly to a receiving stream or through a MS4 from your site. It eventually reaches a receiving water body such as a local stream or lake, possibly via a drainage ditch. You must provide the name of the water body that receives the discharge from the site (a local stream or lake).

If your site has more than one outfall you need to include the name of the first water body for each outfall, if they are different.

k) Identify the segment number(s) of the classified water body(s)

Identify the classified segment number(s) receiving a discharge directly or indirectly. Enter the following link into your internet browser to find the segment number of the classified water body where stormwater will flow from the site:

www.tceq.texas.gov/waterquality/monitoring/viewer.html or by contacting the TCEQ Water Quality Division at (512) 239-4671 for assistance.

You may also find the segment number in TCEQ publication GI-316 by entering the following link into your internet browser: www.tceq.texas.gov/publications/gi/gi-316 or by contacting the TCEQ Water Quality Division at (512) 239-4671 for assistance.

If the discharge is into an unclassified receiving water and then crosses state lines prior to entering a classified segment, select the appropriate watershed:

- 0100 (Canadian River Basin)
- 0200 (Red River Basin)
- 0300 (Sulfur River Basin)
- 0400 (Cypress Creek Basin)
- 0500 (Sabine River Basin)

Call the Water Quality Assessments section at 512-239-4671 for further assistance.

l) Discharge into MS4 – Identify the MS4 Operator

The discharge may initially be into a municipal separate storm sewer system (MS4). If the stormwater discharge is into an MS4, provide the name of the entity that operates the MS4 where the stormwater discharges. An MS4 operator is often a city, town, county, or utility district, but possibly can be another form of government. Please note that the Construction General Permit requires the Operator to supply the MS4 with a

copy of the NOI submitted to TCEQ. For assistance, you may call the technical staff at 512-239-4671.

m) Discharges to the Edwards Aquifer Recharge Zone and Certification

The general permit requires the approved Contributing Zone Plan or Water Pollution Abatement Plan to be included or referenced as a part of the Stormwater Pollution Prevention Plan.

See maps on the TCEQ website to determine if the site is located within the Recharge Zone, Contributing Zone, or Contributing Zone within the Transition Zone of the Edwards Aquifer by entering the following link into an internet browser:

www.tceq.texas.gov/field/eapp/viewer.html or by contacting the TCEQ Water Quality Division at 512-239-4671 for assistance.

If the discharge or potential discharge is within the Recharge Zone, Contributing Zone, or Contributing Zone within the Transition Zone of the Edwards Aquifer, a site-specific authorization approved by the Executive Director under the Edwards Aquifer Protection Program (30 TAC Chapter 213) is required before construction can begin.

For questions regarding the Edwards Aquifer Protection Program, contact the appropriate TCEQ Regional Office. For projects in Hays, Travis and Williamson Counties: Austin Regional Office, 12100 Park 35 Circle, Austin, TX 78753, 512-339-2929. For Projects in Bexar, Comal, Kinney, Medina and Uvalde Counties: TCEQ San Antonio Regional Office, 14250 Judson Rd., San Antonio, TX 78233-4480, 210-490-3096.

Section 5. NOI CERTIFICATION

Note: Failure to indicate Yes to all of the certification items may result in denial of coverage under the general permit.

a) Certification of Understanding the Terms and Conditions of Construction General Permit (TXR150000)

Provisional coverage under the Construction General Permit (TXR150000) begins 7 days after the completed paper NOI is postmarked for delivery to the TCEQ. Electronic applications submitted through ePermits have immediate provisional coverage. You must obtain a copy and read the Construction General Permit before submitting your application. You may view and print the Construction General Permit for which you are seeking coverage at the TCEQ web site by entering the following link into an internet browser: www.tceq.texas.gov/goto/construction or you may contact the TCEQ Stormwater processing Center at 512-239-3700 for assistance.

b) Certification of Legal Name

The full legal name of the applicant as authorized to do business in Texas is required. The name must be provided exactly as filed with the Texas Secretary of State (SOS), or on other legal documents forming the entity, that is filed in the county where doing business. You may contact the SOS at 512-463 5555, for more information related to filing in Texas.

c) Understanding of Notice of Termination

A permittee shall terminate coverage under the Construction General Permit through the submittal of a NOT when the operator of the facility changes, final stabilization has

been reached, the discharge becomes authorized under an individual permit, or the construction activity never began at this site.

d) Certification of Stormwater Pollution Prevention Plan

The SWP3 identifies the areas and activities that could produce contaminated runoff at your site and then tells how you will ensure that this contamination is mitigated. For example, in describing your mitigation measures, your site's plan might identify the devices that collect and filter stormwater, tell how those devices are to be maintained, and tell how frequently that maintenance is to be carried out. You must develop this plan in accordance with the TCEQ general permit requirements. This plan must be developed and implemented before you complete this NOI. The SWP3 must be available for a TCEQ investigator to review on request.

Section 6. APPLICANT CERTIFICATION SIGNATURE

The certification must bear an original signature of a person meeting the signatory requirements specified under 30 Texas Administrative Code (TAC) §305.44.

If you are a corporation:

The regulation that controls who may sign an NOI or similar form is 30 Texas Administrative Code §305.44(a)(1) (see below). According to this code provision, any corporate representative may sign an NOI or similar form so long as the authority to sign such a document has been delegated to that person in accordance with corporate procedures. By signing the NOI or similar form, you are certifying that such authority has been delegated to you. The TCEQ may request documentation evidencing such authority.

If you are a municipality or other government entity:

The regulation that controls who may sign an NOI or similar form is 30 Texas Administrative Code §305.44(a)(3) (see below). According to this code provision, only a ranking elected official or principal executive officer may sign an NOI or similar form. Persons such as the City Mayor or County Commissioner will be considered ranking elected officials. In order to identify the principal executive officer of your government entity, it may be beneficial to consult your city charter, county or city ordinances, or the Texas statute(s) under which your government entity was formed. An NOI or similar document that is signed by a government official who is not a ranking elected official or principal executive officer does not conform to §305.44(a)(3). The signatory requirement may not be delegated to a government representative other than those identified in the regulation. By signing the NOI or similar form, you are certifying that you are either a ranking elected official or principal executive officer as required by the administrative code. Documentation demonstrating your position as a ranking elected official or principal executive officer may be requested by the TCEQ.

If you have any questions or need additional information concerning the signatory requirements discussed above, please contact the TCEQ's Environmental Law Division at 512-239-0600.

30 Texas Administrative Code

§305.44. Signatories to Applications

(a) All applications shall be signed as follows.

(1) For a corporation, the application shall be signed by a responsible corporate officer. For purposes of this paragraph, a responsible corporate officer means a president, secretary, treasurer, or vice-president of the corporation in charge of a principal business function, or any other person who performs similar policy or decision-making functions for the

corporation; or the manager of one or more manufacturing, production, or operating facilities employing more than 250 persons or having gross annual sales or expenditures exceeding \$25 million (in second-quarter 1980 dollars), if authority to sign documents has been assigned or delegated to the manager in accordance with corporate procedures. Corporate procedures governing authority to sign permit or post-closure order applications may provide for assignment or delegation to applicable corporate positions rather than to specific individuals.

(2) For a partnership or sole proprietorship, the application shall be signed by a general partner or the proprietor, respectively.

(3) For a municipality, state, federal, or other public agency, the application shall be signed by either a principal executive officer or a ranking elected official. For purposes of this paragraph, a principal executive officer of a federal agency includes the chief executive officer of the agency, or a senior executive officer having responsibility for the overall operations of a principal geographic unit of the agency (e.g., regional administrator of the EPA).

Texas Commission on Environmental Quality General Permit Payment Submittal Form

Use this form to submit your Application Fee only if you are mailing your payment.

Instructions:

- Complete items 1 through 5 below:
- Staple your check in the space provided at the bottom of this document.
- *Do not mail this form with your NOI form.*
- *Do not mail this form to the same address as your NOI.*

Mail this form and your check to either of the following:

By Regular U.S. Mail

Texas Commission on Environmental Quality
Financial Administration Division
Cashier's Office, MC-214
P.O. Box 13088
Austin, TX 78711-3088

By Overnight or Express Mail

Texas Commission on Environmental Quality
Financial Administration Division
Cashier's Office, MC-214
12100 Park 35 Circle
Austin, TX 78753

Fee Code: GPA General Permit: TXR150000

1. Check or Money Order No:
2. Amount of Check/Money Order:
3. Date of Check or Money Order:
4. Name on Check or Money Order:
5. NOI Information:

If the check is for more than one NOI, list each Project or Site (RE) Name and Physical Address exactly as provided on the NOI. **Do not submit a copy of the NOI with this form, as it could cause duplicate permit application entries!**

If there is not enough space on the form to list all of the projects or sites the authorization will cover, then attach a list of the additional sites.

Project/Site (RE) Name:

Project/Site (RE) Physical Address:

Staple the check or money order to this form in this space.

SIGNATURE PAGE:

Applicant's Signature

3-29-24
Date

THE STATE OF TEXAS §

County of TRAVIS §

BEFORE ME, the undersigned authority, on this day personally appeared Curtis Thigpen known to me to be the person whose name is subscribed to the foregoing instrument, and acknowledged to me that (s)he executed same for the purpose and consideration therein expressed.

GIVEN under my hand and seal of office on this 29th day of March, 2024.



NOTARY PUBLIC

Mikayla Grimm
Typed or Printed Name of Notary

MY COMMISSION EXPIRES: July 6, 2027

Application Fee Form

Texas Commission on Environmental Quality

Name of Proposed Regulated Entity: Bandera Ranch

Regulated Entity Location: 15030 Bandera Rd., Helotes, TX Bexar County

Name of Customer: Helotes Bandera Ranch, LP

Contact Person: Curtis Thigpen

Phone: 512-934-8293

Customer Reference Number (if issued): CN 606209005

Regulated Entity Reference Number (if issued): RN 111858122

Austin Regional Office (3373)

Hays

Travis

Williamson

San Antonio Regional Office (3362)

Bexar

Medina

Uvalde

Comal

Kinney

Application fees must be paid by check, certified check, or money order, payable to the **Texas Commission on Environmental Quality**. Your canceled check will serve as your receipt. **This form must be submitted with your fee payment.** This payment is being submitted to:

Austin Regional Office

San Antonio Regional Office

Mailed to: TCEQ - Cashier

Overnight Delivery to: TCEQ - Cashier

Revenues Section

Mail Code 214

P.O. Box 13088

Austin, TX 78711-3088

12100 Park 35 Circle

Building A, 3rd Floor

Austin, TX 78753

(512)239-0357

Site Location (Check All That Apply):

Recharge Zone

Contributing Zone

Transition Zone

<i>Type of Plan</i>	<i>Size</i>	<i>Fee Due</i>
Water Pollution Abatement Plan, Contributing Zone Plan: One Single Family Residential Dwelling	Acres	\$
Water Pollution Abatement Plan, Contributing Zone Plan: Multiple Single Family Residential and Parks	Acres	\$
Water Pollution Abatement Plan, Contributing Zone Plan: Non-residential	31.463 Acres	\$ 6,500
Sewage Collection System	L.F.	\$
Lift Stations without sewer lines	Acres	\$
Underground or Aboveground Storage Tank Facility	Tanks	\$
Piping System(s)(only)	Each	\$
Exception	Each	\$
Extension of Time	Each	\$

Signature: 

Date: 04/15/2024

Application Fee Schedule

Texas Commission on Environmental Quality

Edwards Aquifer Protection Program 30 TAC Chapter 213 (effective 05/01/2008)

Water Pollution Abatement Plans and Modifications

Contributing Zone Plans and Modifications

<i>Project</i>	<i>Project Area in Acres</i>	<i>Fee</i>
One Single Family Residential Dwelling	< 5	\$650
Multiple Single Family Residential and Parks	< 5	\$1,500
	5 < 10	\$3,000
	10 < 40	\$4,000
	40 < 100	\$6,500
	100 < 500	\$8,000
	≥ 500	\$10,000
Non-residential (Commercial, industrial, institutional, multi-family residential, schools, and other sites where regulated activities will occur)	< 1	\$3,000
	1 < 5	\$4,000
	5 < 10	\$5,000
	10 < 40	\$6,500
	40 < 100	\$8,000
	≥ 100	\$10,000

Organized Sewage Collection Systems and Modifications

<i>Project</i>	<i>Cost per Linear Foot</i>	<i>Minimum Fee- Maximum Fee</i>
Sewage Collection Systems	\$0.50	\$650 - \$6,500

Underground and Aboveground Storage Tank System Facility Plans and Modifications

<i>Project</i>	<i>Cost per Tank or Piping System</i>	<i>Minimum Fee- Maximum Fee</i>
Underground and Aboveground Storage Tank Facility	\$650	\$650 - \$6,500

Exception Requests

<i>Project</i>	<i>Fee</i>
Exception Request	\$500

Extension of Time Requests

<i>Project</i>	<i>Fee</i>
Extension of Time Request	\$150



TCEQ Core Data Form

For detailed instructions on completing this form, please read the Core Data Form Instructions or call 512-239-5175.

SECTION I: General Information

1. Reason for Submission (If other is checked please describe in space provided.)		
<input checked="" type="checkbox"/> New Permit, Registration or Authorization (Core Data Form should be submitted with the program application.)		
<input type="checkbox"/> Renewal (Core Data Form should be submitted with the renewal form)	<input type="checkbox"/> Other	
2. Customer Reference Number (if issued)	Follow this link to search for CN or RN numbers in Central Registry**	3. Regulated Entity Reference Number (if issued)
CN 606209005		RN 111858122

SECTION II: Customer Information

4. General Customer Information		5. Effective Date for Customer Information Updates (mm/dd/yyyy)	
<input checked="" type="checkbox"/> New Customer <input type="checkbox"/> Update to Customer Information <input type="checkbox"/> Change in Regulated Entity Ownership <input type="checkbox"/> Change in Legal Name (Verifiable with the Texas Secretary of State or Texas Comptroller of Public Accounts)			
<i>The Customer Name submitted here may be updated automatically based on what is current and active with the Texas Secretary of State (SOS) or Texas Comptroller of Public Accounts (CPA).</i>			
6. Customer Legal Name (If an individual, print last name first: eg: Doe, John)		<i>If new Customer, enter previous Customer below:</i>	
Helotes Bandera Ranch, LP			
7. TX SOS/CPA Filing Number	8. TX State Tax ID (11 digits)	9. Federal Tax ID (9 digits)	10. DUNS Number (if applicable)
0804747721	32086461731	92-0836859	110813049
11. Type of Customer:		Partnership: <input type="checkbox"/> General <input checked="" type="checkbox"/> Limited	
<input type="checkbox"/> Corporation Government: <input type="checkbox"/> City <input type="checkbox"/> County <input type="checkbox"/> Federal <input type="checkbox"/> Local <input type="checkbox"/> State <input type="checkbox"/> Other		<input type="checkbox"/> Individual <input type="checkbox"/> Sole Proprietorship <input type="checkbox"/> Other:	
12. Number of Employees		13. Independently Owned and Operated?	
<input checked="" type="checkbox"/> 0-20 <input type="checkbox"/> 21-100 <input type="checkbox"/> 101-250 <input type="checkbox"/> 251-500 <input type="checkbox"/> 501 and higher		<input type="checkbox"/> Yes <input type="checkbox"/> No	
14. Customer Role (Proposed or Actual) – as it relates to the Regulated Entity listed on this form. Please check one of the following			
<input checked="" type="checkbox"/> Owner <input type="checkbox"/> Operator <input type="checkbox"/> Owner & Operator <input type="checkbox"/> Other: <input type="checkbox"/> Occupational Licensee <input type="checkbox"/> Responsible Party <input type="checkbox"/> VCP/BSA Applicant			
15. Mailing Address:		1509 Old West 38 th St., Suite 3	
City	Austin	State	TX
ZIP	78731	ZIP + 4	6328
16. Country Mailing Information (if outside USA)		17. E-Mail Address (if applicable)	
		cthigpen@paravelcap.com	
18. Telephone Number		19. Extension or Code	20. Fax Number (if applicable)

SECTION III: Regulated Entity Information**21. General Regulated Entity Information** *(If "New Regulated Entity" is selected, a new permit application is also required.)*
 New Regulated Entity
 Update to Regulated Entity Name
 Update to Regulated Entity Information

The Regulated Entity Name submitted may be updated, in order to meet TCEQ Core Data Standards (removal of organizational endings such as Inc, LP, or LLC).

22. Regulated Entity Name *(Enter name of the site where the regulated action is taking place.)*

Bandera Ranch

23. Street Address of the Regulated Entity:*(No PO Boxes)*

15030 Bandera Road

City

Helotes

State

TX

ZIP

ZIP + 4

24. County

Bexar

If no Street Address is provided, fields 25-28 are required.

25. Description to Physical Location:**26. Nearest City**

State

Nearest ZIP Code

Latitude/Longitude are required and may be added/updated to meet TCEQ Core Data Standards. (Geocoding of the Physical Address may be used to supply coordinates where none have been provided or to gain accuracy).

27. Latitude (N) In Decimal:**28. Longitude (W) In Decimal:**

Degrees

Minutes

Seconds

Degrees

Minutes

Seconds

29. Primary SIC Code

(4 digits)

30. Secondary SIC Code

(4 digits)

31. Primary NAICS Code

(5 or 6 digits)

32. Secondary NAICS Code

(5 or 6 digits)

1522

1542

33. What is the Primary Business of this entity? *(Do not repeat the SIC or NAICS description.)*

Multifamily and Commercial Development

34. Mailing Address:

Address:

City

State

ZIP

ZIP + 4

35. E-Mail Address:**36. Telephone Number****37. Extension or Code****38. Fax Number** *(if applicable)*

() -

() -

39. TCEQ Programs and ID Numbers Check all Programs and write in the permits/registration numbers that will be affected by the updates submitted on this form. See the Core Data Form instructions for additional guidance.

<input type="checkbox"/> Dam Safety	<input type="checkbox"/> Districts	<input checked="" type="checkbox"/> Edwards Aquifer	<input type="checkbox"/> Emissions Inventory Air	<input type="checkbox"/> Industrial Hazardous Waste
<input type="checkbox"/> Municipal Solid Waste	<input type="checkbox"/> New Source Review Air	<input type="checkbox"/> OSSF	<input type="checkbox"/> Petroleum Storage Tank	<input type="checkbox"/> PWS
<input type="checkbox"/> Sludge	<input type="checkbox"/> Storm Water	<input type="checkbox"/> Title V Air	<input type="checkbox"/> Tires	<input type="checkbox"/> Used Oil
<input type="checkbox"/> Voluntary Cleanup	<input type="checkbox"/> Wastewater	<input type="checkbox"/> Wastewater Agriculture	<input type="checkbox"/> Water Rights	<input type="checkbox"/> Other:

SECTION IV: Preparer Information

40. Name:	Matthew G. Matney		41. Title:	Project Manager
42. Telephone Number	43. Ext./Code	44. Fax Number	45. E-Mail Address	
(210) 321-3419		() -	Matthew.Matney@kimley-horn.com	

SECTION V: Authorized Signature

46. By my signature below, I certify, to the best of my knowledge, that the information provided in this form is true and complete, and that I have signature authority to submit this form on behalf of the entity specified in Section II, Field 6 and/or as required for the updates to the ID numbers identified in field 39.

Company:	Helotes Bandera Ranch, LP	Job Title:	Owner
Name (In Print):	Curtis Thigpen	Phone:	(512) 934- 8923
Signature:		Date:	3.29.24